

THE ART OF  
**DESIGN**

LUXURY HOME INTERIORS

£4.95 • ISSUE 62



CLERKENWELL DESIGN WEEK 2023 /  
TILES BY WOW DESIGN /  
THE BEAUTY OF BESPOKE JOINERY



JESSICA ZOOB  
*Is back in Sussex*

Studio visits by request  
email [info@jessicazoob.com](mailto:info@jessicazoob.com) for available works.

[www.jessicazoob.com](http://www.jessicazoob.com)

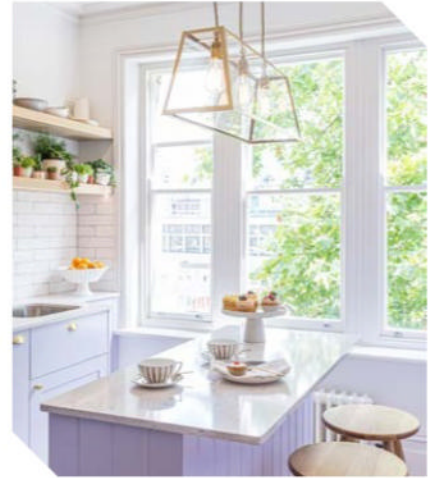

## CONTENTS

**12**

### BUBBLETECTURE, EDIBLE TABLESCAPE AND MODERN CRAFT

Clerkenwell Design Week (CDW), now in its 12th edition, will return to EC1 London between 23 – 25 May 2023.

**42**

### BLOOMSBURY MANSION APARTMENT

LLI Design were commissioned to completely redesign and refurbish a period apartment in a grand mansion block in the heart of Bloomsbury London.

**26**

### TILES BY WOW DESIGN AT JUNO HOUSE, THE FIRST WOMEN'S CLUB IN SPAIN

A former factory in the centre of Barcelona has been converted into a multipurpose space for women.

**56**

### TIMELESS MODERN HOUSE IN CHICAGO WITH THE KASUAL COLLECTION

Karim Rashid's casual and modern representation by Mid Century Studio.

#### Editor in Chief

Antony Holter  
T: 01304 806039  
E: editor@mhmagazine.co.uk

#### Editor

Rebecca Keating  
T: 01304 806039  
E: rebecca@theartofdesignmagazine.com

#### Publishing Director

Martin Holmes  
T: 01304 806039  
E: martin@mhmagazine.co.uk

#### Sales Director

Courtney Yorke  
T: 01227 936976  
E: courtney@theartofdesignmagazine.com

#### Digital Manager

Jamie Bullock  
T: 01227 936971  
E: jamie@mhmagazine.co.uk

#### Business Manager

Josh Holmes  
T: 01304 806039  
E: josh@mhmagazine.co.uk

#### Studio Designer

Sarah Johnson  
E: sarah.johnson@mhmagazine.co.uk

#### Accounts Department

Alison Holmes  
T: 01304 806039  
E: accounts@mhmediaglobal.com

#### MH Media Global Ltd

18/20 Newington Road  
Ramsgate  
Kent CT12 6EE



Cover Image Courtesy of:  
DelightFULL



The Art of Design  
is proud partners with

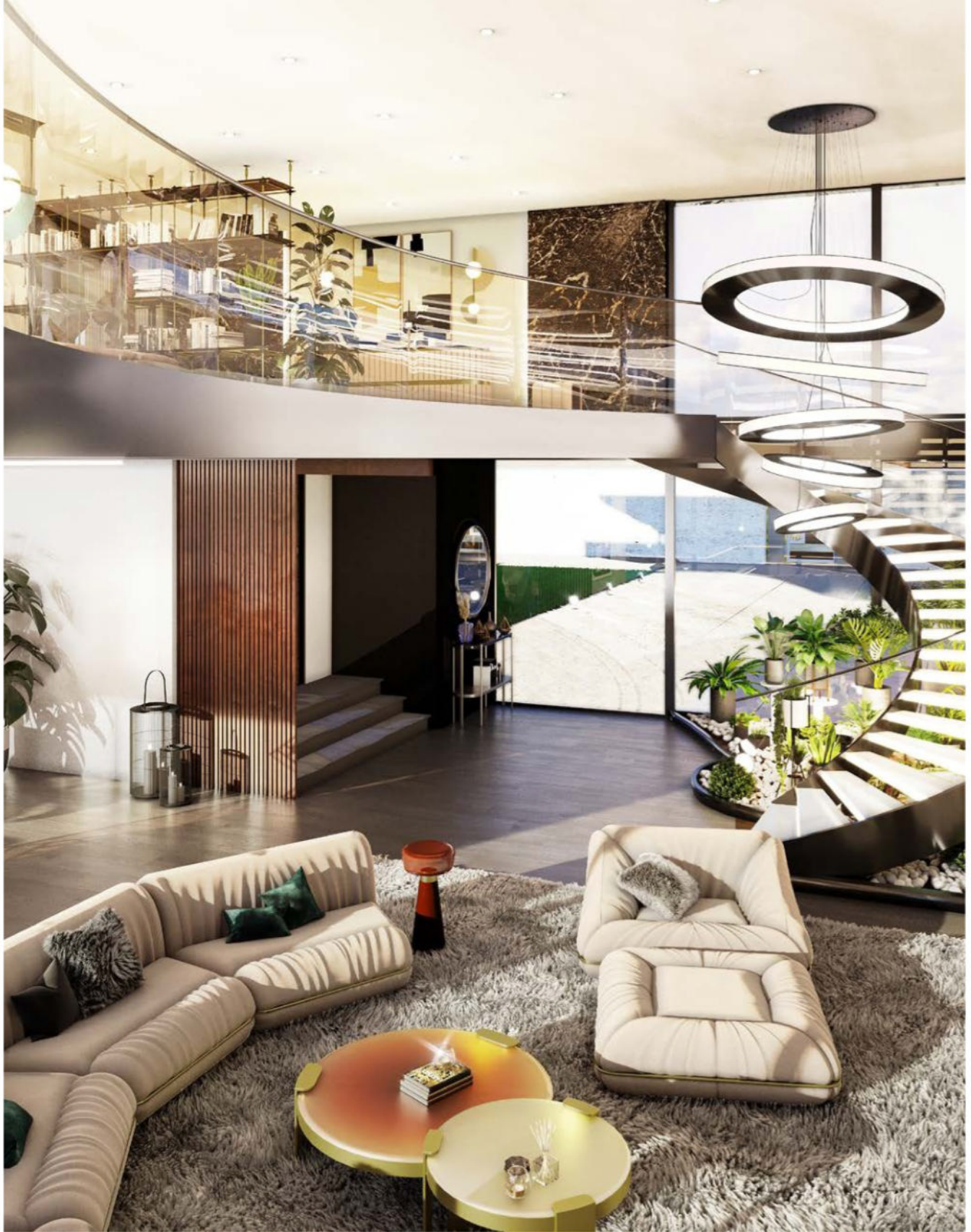

NEUTRAL MODERN HOME IN  
MILAN WITH DRAGA & AUREL  
**INNOVATIVE, GROOVY &  
SOPHISTICATED**



## HOUSE

This magnificent luxury home is located in the fashion and design capital of the world, famous for having some of the best design stores in the world is Milan. With its mid-century inspiration, the house conveys a vibrant and irresistible feeling in its pieces, with its mixtures of patterns, colors, shapes, textures and materials, giving it another life. The vision of this project is to create objects that describe “eras and emotions”. This house with a vibe of the late seventies and eighties, an era that brought together some of the most dynamic and innovative thinking, with the incentive to unleash creativity, hedonism, rebellion and emancipation from the dominant culture. Composed of two floors, this house, despite having only two bedrooms, is a large house with very functional and incredible spaces. With a beautiful outdoor area with swimming pool, this project is anyone’s dream!

## ENTRANCE

Starting from the ground floor, you enter the house and find a staircase from another world, surrounded by glass and illuminated in each step. With the huge Marcus lamp from the Mid Century Club. With a small modern garden composed of various types of plants and white stones, this entrance makes us curious to know the rest of the house.

## LIVING ROOM

The living room is a very different area from the others described so far, because in general it presents much more neutral tones, such as nudes, and has many color touches in small pieces, such as pictures, pillows, the Caprice center tables, which are in orange with gold tones, and the Taboo side table which is in red tones. Besides the incredible view of the outside area of the house, it has a stone wall that immediately teleports us to the middle of nature, giving a more rustic and intimate style at the same time.





The lighting along with the long, sophisticated fireplace give us the cozy touch we need. For Draga & Aurel "We share a mutual passion for vintage, a reverence for mid-century design, as well as the desire for cinema with a little glamour mixed in" and nothing represents this thought better than the Xenon modular sofa, which seems to have been designed exactly for this living room, as it

provides individual comfort and with its various modules multiple compositions can be created for areas of different sizes, never compromising on its functionality and comfort. To complement the sofa we have the Xenon armchair with features very similar to the sofa, which teleports us to the mode streets of the late 70s in New York.

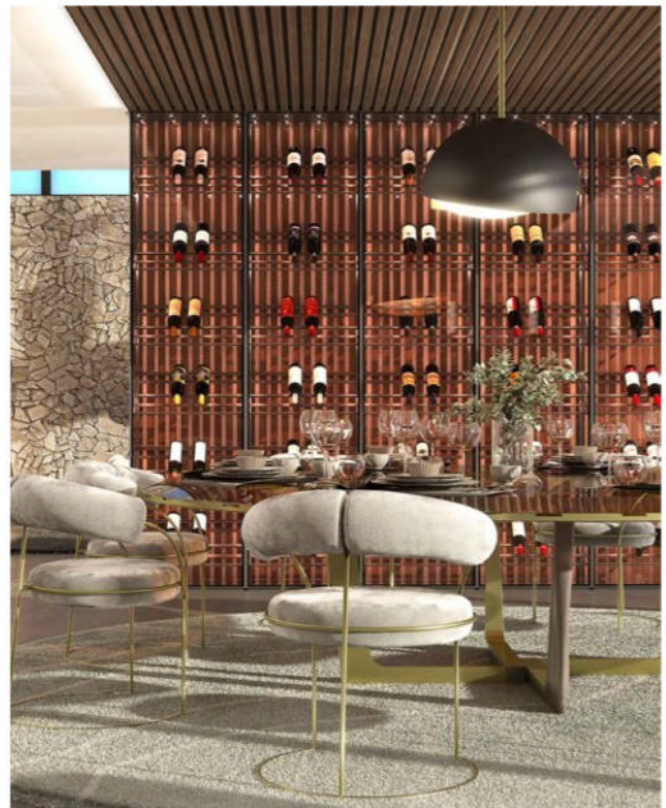

## DINING AREA

The kitchen and the dining room have no partition, although they are very well defined. There are two dining areas, but the kitchen is for quicker meals and with few people while the dining room is designed for more complex meals and with a higher number of people. Darker tones reign in the constitution of this kitchen, where cherry wood is the most used material. In the kitchen we can see several light points on the cabinets where the dishes are exposed and even on the counter, which brings us an air of sophistication, technology and even gives us a sense of coziness because they are strategic light points and not very strong, creating a cozy environment.



In the dining area, we have the incredible Maxime dining table, round, all in ruby glass and with feet in polished golden brass complemented with the Roxy dining chairs, elegant that adapt to any style and project. These two pieces are the fruit of a vibrant

collection designed in the Draga & Aurel X Essential Home & DelightFULL collection, the "Night Fever Collection". As a prop we have the plants that balance this environment, all this sophistication is broken with a bit of nature that transports us a little to the outside. We still have a huge "wall" where the wine cellar is located, which seems to be an extension of the kitchen, because the cherry wood wall that covers the kitchen extends to the ceiling ending in the wall of the wine cellar.





All lit with the latest LED light technology, with a steel structure and glass cover, the wine cellar is perhaps what best represents simplicity and elegance in this room. The wine cellar also serves as a divider between the dining room and the living room.

## OFFICE

Going up one floor, we have a lounge where reading can be done in a relaxed way, composed of the Mulligan bookcase filled with stories and adventures to read, consisting of an office area with an incredible view of the outdoor area, where you can work quietly on the Edith desk from Essential Home. This piece has a unique character, and can easily be the star of your work corner, inspired by mid-century the class of this piece is indisputable.





## MASTER BEDROOM

Throughout the master bedroom there is a sophisticated and luxurious aura, the use of a rustic style in the stone of the wall behind the bed, with a more luxurious style in the use of golds and marble in front of the bed. The use of a darker palette brings us luxury and comfort at the same time. Minelli bed from Essential Home is the main protagonist of this space and its perfect combination with the side table Taboo in ruby color. To complement the room we



have the master bathroom, composed by two sinks and two Diamond small mirrors and a bathtub by Maison Valentina, where glamour is the key word to describe this bathroom.



FOLLOW US: [@essential\\_home](https://www.instagram.com/essential_home)

Images: [@Essential Home](https://www.instagram.com/Essential_Home)

## ABOUT US

**Essential Home is the epitome of bohemian retro design.**

Its mid-century modern lines merge from important historical references from the '30s and 60's. The harmony of masculine and feminine, classic and contemporary, high and low, is integral to the brand's sense of style. We deal with different, intimate and cosy ambiances that express elegance and luxury.

Conveyed by the use of high-quality materials, Essential Home pieces have a mid-century modern signature that makes it irresistible to us all. We intend to create time travels through a strong evocative connotation of the stunning era between the 30's and 60's so our products are a true combination of colours, matter and design. Essential Home creates a connection between the past and present, delivering the perfect combination of contemporary and modern pieces.



The  
**Solid Wood**  
Flooring Company

thesolidwoodflooringcompany.com

Manufacturing & Trade Specialists

# Sustainable, Engineered Wood Flooring

At The Solid Wood Flooring Company we pride ourselves on the service we offer, with high quality products, good service and competitive pricing. Sustainability is in our DNA and innovation is at the heart of what we do. We are very conscious of our environment and will only supply fully sustainable wood flooring. We are FSC® certified and PEFC™ certified.

Our collection is perfect for commercial and residential projects and includes engineered wood boards, decorative herringbone and chevron parquet and basketweave. Built on service, quality and sustainability, we take the lead in developing high quality, sustainable flooring.

## Contact us

01666 504 015  
info@thesolidwoodflooringcompany.com  
thesolidwoodflooringcompany.com



Manufacturers offering services to Architects,  
Designers, Developers & Contractors



Le Bistro Pierre



Viking Museum York



Park Drive Canary Wharf



## The Future of Flooring

Our sister company Impervia® provides one of the most sustainable VOC free flooring available today. We're proud to present the future of high-quality sustainable flooring, perfect to fit the pieces of your project's puzzle.

Designed for durability, our range of luxury herringbone and planks are built to last. Impervia® is the perfect solution to fit in any space whether its commercial or residential. We know the finish matters, so let our flooring bring the look of luxury to your project.

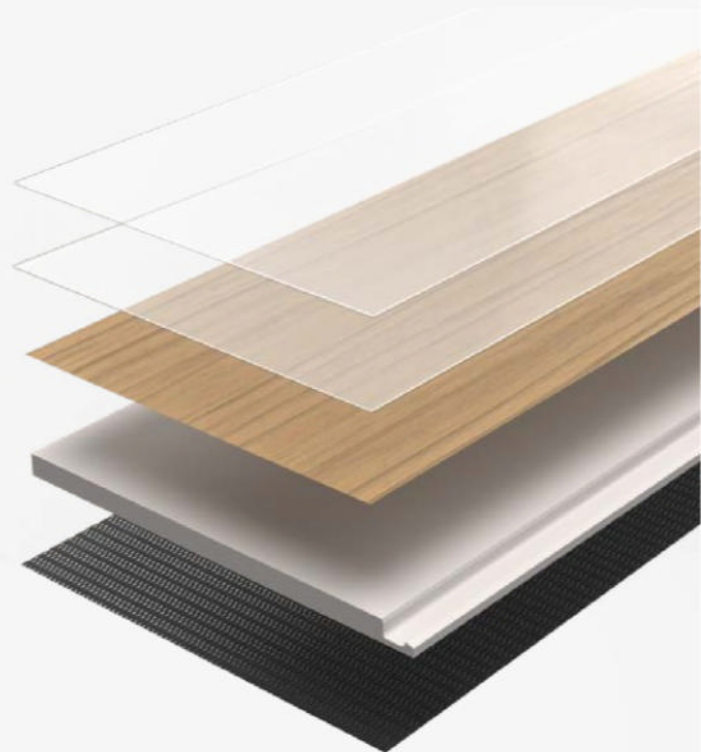

**Get in touch today**

**Telephone:** 01666 504 015

**Email:** [contact@impervia.co.uk](mailto:contact@impervia.co.uk)

**Visit:** [impervia.co.uk](http://impervia.co.uk)



# BUBBLETECTURE, EDIBLE TABLESCAPE AND MODERN CRAFT: HIGHLIGHTS AT CLERKENWELL DESIGN WEEK 2023

## 23 – 25 MAY 2023

Clerkenwell Design Week (CDW), now in its 12th edition, will return to EC1 London between 23 – 25 May 2023. Taking place across the whole of Clerkenwell, a neighbourhood renowned for its high concentration of architects and designers, the festival is set to offer its biggest programme yet – featuring more than 600 events and, for the first time, merging with its sister show, Design London.

Box K2 on Clerkenwell Road  
by artist Steve Messam

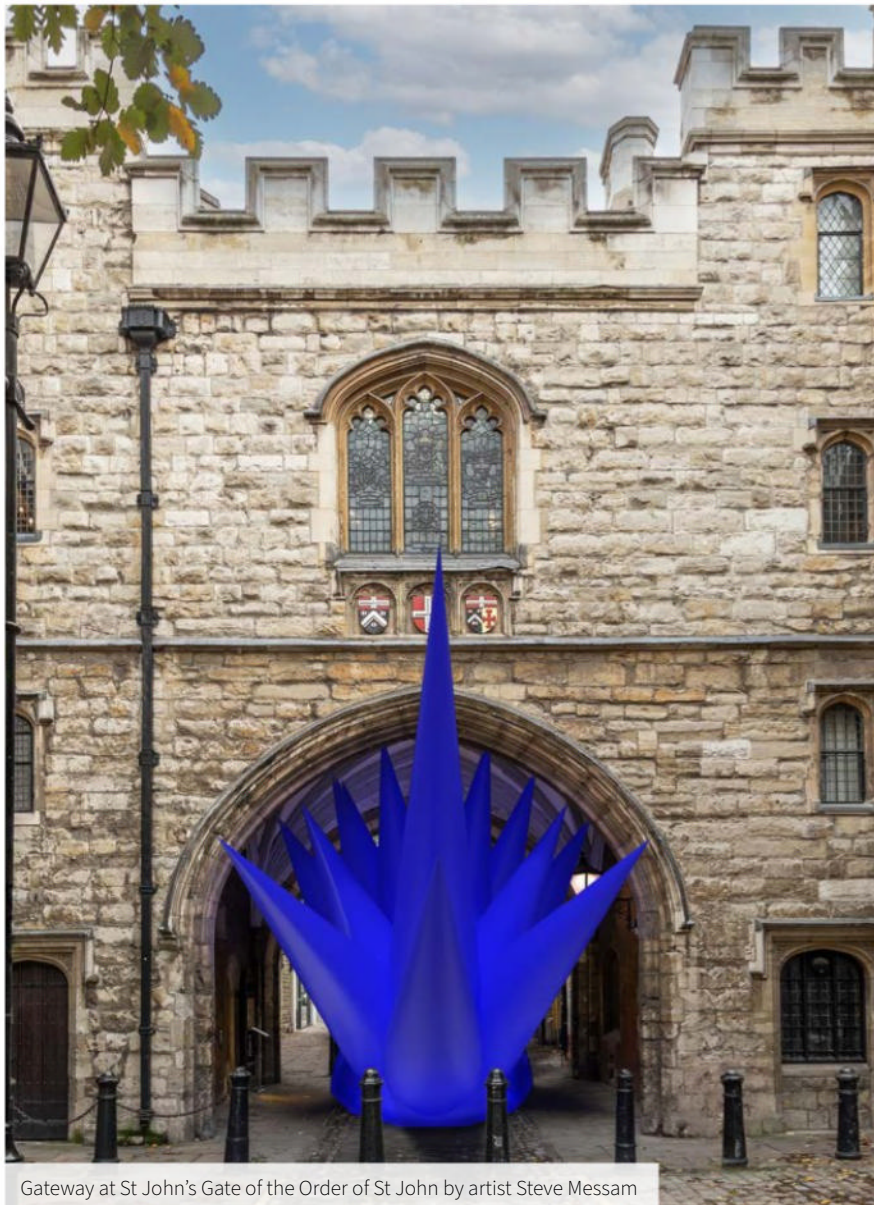

Gateway at St John's Gate of the Order of St John by artist Steve Messam

CDW 2023 sees a total of 12 exhibition venues across Clerkenwell including: Design Fields, Contract, Light, Project, Elements, British Collection, Detail, Platform, Ceramics of Italy, Old Sessions House (the festival hub), and two new additions – Catapult and The Garden. While these unique venues will present over 300 design brands and emerging talent covering furniture, kitchens and bathrooms, materials and surfaces, textiles, decorative accessories, and lighting, an extensive network of more than 130 local showroom partners will host product launches, workshops and talks over the three days of the festival.

## ARCHITECTURE GOES INFLATABLE

Headlining this year's CDW Presents programme is a specially commissioned installation by British artist, Steve Messam – who exhibits internationally and is well



SYMBIOCENE LIVING: Mycelium Building Block by PLP Architecture

known for his large-scale, inflatable artwork reimagining our everyday surroundings. At the festival, the County Durham-based artist will bring his distinctive public art – sponsored by 3D design software company, SketchUp – to St John’s Gate of the Order of St John. This site-specific piece, titled Gateway and measuring 6m (height) by 15.5m (length), will feature 27 giant spikes hand-sewn in a striking blue textile. It forms part of Messam’s ongoing art series taking over historic architectural sites – and inviting the public to examine their environment in a new light through its deliberately ambiguous shape and size.

“Gateway offers a dynamic and unforgettable sensory experience,” says Messam. “While the spikes tower above the public as they pass through the gate, the bespoke piece traces the internal space between the arches before bursting out beyond the bounds of the building.”

In addition to Gateway, visitors will have the opportunity to experience Messam’s artistic treatment of the iconic telephone

boxes – sponsored by Budvar. K6, originally designed by Sir Giles Gilbert Scott for the coronation of George V in 1935, is one of the most recognised telephone boxes; while K2 – also designed by Scott in 1924 – was the first national telephone box, many of which were initially installed in Clerkenwell. Spread over three locations, the former is located on Cowcross Street, and the latter can be found on Clerkenwell Road as well as outside St James’s Church.

## SUSTAINABILITY IS THE NORM

Creating a more sustainable way of living – from biodiversity to reduce-reuse-recycle – remains a key subject matter for many design manufacturers and makers. Using modern technology and the latest research, many explore and propose new ways to challenge the status quo while tackling these industry-wide issues with a global outlook.

As part of the CDW Presents series, SYMBIOCENE LIVING: Mycelium Building Block is an interpretive, artistic mycelium

installation that encourages the public to envision and engage with fungi architecture. While the modular feature is made of mycelium blocks with a 3D printed timber shell, the blocks – each similar in size to a watermelon – will be arranged to create a different formation incorporating abstract seating and towers on each day of the festival.

Set to be situated outside Clerkenwell & Social on St John’s Square, this one-off installation is designed by East London-based PLP Architecture – which has produced some of the world’s greenest and most intelligent designs through a profound commitment to social, economic and environmental values.

Over at Old Sessions House, Heiter X – a sustainable food design and experience studio founded by Estonia-based Helis Heiter – will launch its first collection of sculptural tableware in collaboration with Krohwin. Crafted using traditional building techniques and innovative 3D clay printing technology, the Mound Collection is made from raw clay and natural carnauba wax – as well as repurposed food industry waste including buckwheat and hemp shells. The collection symbolises the mounds of food wasted every day, serving as a visual reminder of the need for more conscious consumption and waste reduction.

The new tableware will be shown alongside Terra Firma, an edible tablescape aimed to spark conversation and inspire change in the way we think about and interact with food.

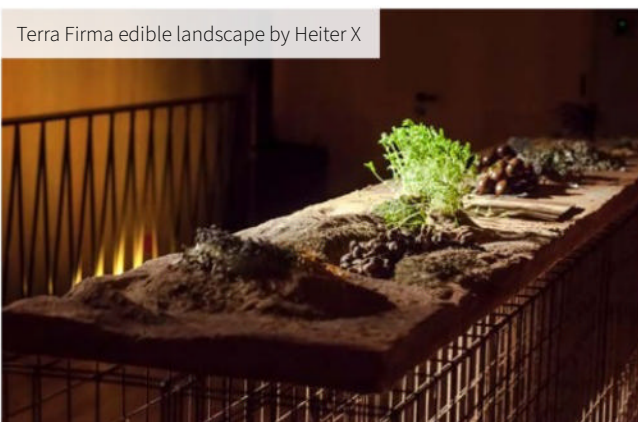

Terra Firma edible landscape by Heiter X

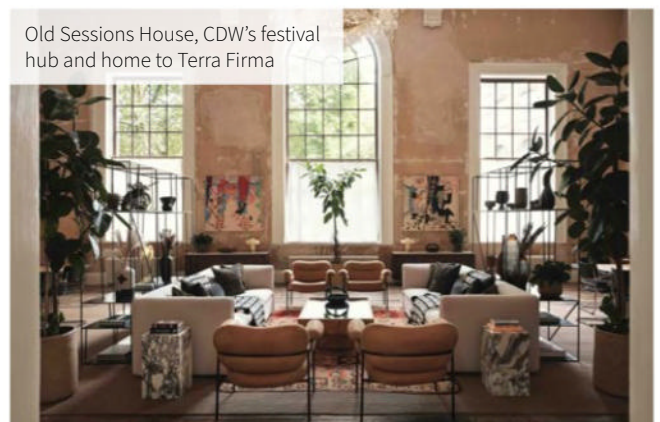

Old Sessions House, CDW’s festival hub and home to Terra Firma



Recork x Sugo Cork Rugs

Launched in 2022, Kent-based Recork (Project) specialises in stylish cork flooring made from 85% natural cork, harvested from trees grown in well-managed cork oak Montado. According to the eco-conscious company, it is the only one on the market that takes raw material from the Portuguese oak forests and turns production waste used for stoppers – as well as cork from early harvests – into flooring planks. Recork's stand at CDW will feature its latest rug collection – made entirely from sustainably sourced cork, wool and cotton – in partnership with Portuguese brand Sugo Cork Rugs.

Founded by former textile buyer Charlotte Raffo, The Monkey Puzzle Tree (Light) celebrates the best of creativity and eccentricity from the North of England – by collaborating with Yorkshire artists to locally design and produce fabrics and wallpapers. At CDW, the independent business will showcase its Modernist-inspired wallpaper, Hit The North, featuring artwork by graphic artist Drew Millward printed onto sustainable Portuguese cork.



Hit the North cork wallpaper by The Monkey Puzzle Tree

## OTHER HIGHLIGHTS TO LOOK OUT FOR INCLUDE:

- **Ercol** (British Collection) – Its Marino chair will be relaunched at the festival in sustainable homegrown British timber – as part of its latest partnership with Grown in Britain (GiB);
- **Graphenstone** (Contract) – The brand will present its Ambient Pro+ and Grafclean paint ranges made from natural mineral ingredients and graphene fibres;
- **Morph** (Project) – Set up in 2021, the British company manufactures injection moulded hollow bricks – made from 100% recycled plastic – with a connection system that can create walls, desks, tables and tiered seating. At CDW, it will launch Morph Bio, a new carbon-negative range made from biocomposite material and available in multiple colours;
- **Allsfär** (Project) – The UK-based acoustic expert is known for its products made with at least 60% recycled PET, with each panel produced using the equivalent of 280 recycled plastic

bottles. Expect to see its new wall surface, Fika, at the festival;

- **Parkside** (Showroom) – Its newly launched Sequel Principle will be a key highlight – a recycled composite tile consisting of over 91% recycled content; in particular, unwanted materials from the ceramic and glass industry locally sourced in Spain; and
- **Vepa** (Showroom) – The sustainable furniture manufacturer from the Netherlands will open its new showroom and sustainability education centre at 45 Gee Street during CDW, and show the full colour range of its Felt seating – made from PET plastic bottles – for the first time in the UK.

## MODERN CRAFT PERSEVERES

Our enduring love for the craft as seen in recent years shows no signs of slowing down. The UK continues to lead the way in championing the best talent and finest craftsmanship – and visitors to this year's CDW will not be disappointed by the eclectic mix of independent makers and businesses this country has to offer.

Greek-born, London-based furniture designer and sculptor Kostas Synodis (Platform) will join the festival for the first time. Blending art and design with his signature pared-down aesthetic, the newcomer will exhibit a new foldable low deckchair. Made from three pieces of veneer plywood cut out of the same panels to minimise material use, Notch is inspired by an African palaver chair but reimagined in a more contemporary approach. It can be folded into a 24-mm thick board when not in use.

Now in its 12th year, Curiosa (Light) is renowned for its bespoke hand-blown glass lighting made in its Derbyshire-based old mill studio. At CDW, the brand will present its new Wave chandelier – designed by

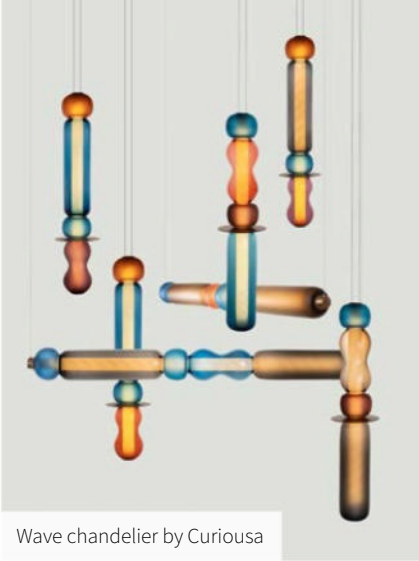

Wave chandelier by Curiousa

its founder Esther Patterson – featuring five hand-formed glass vessels threaded onto beams of light. Including horizontal Ripple Beams and vertical Crest and Cascade pendants, the pieces intersect with each other creating a feeling of effortless interplay and suspension.

Run by husband and wife, Jamie Hoyle and Katherine Mathew, Koda (British Collection) designs and makes bespoke furniture – by hand – in its studio and workshop in Yorkshire. The 10-year-old business will bring its ergonomic height-adjustable walnut desk – an elegant reimagination of a traditional writing desk – as well as its walnut media unit to the festival this May.

Also led by a husband-and-wife duo, Joel and Helena Haran, Cornwall-based Studio Haran (Light) specialises in lighting and furniture with sustainability at its core. Its founders work closely with a team of local skilled craftspeople to produce slip-cast ceramics and woodwork; some of which – including the Dawn pendant and wall light – will be on show at CDW.

Fibre artist Livi Hecht of London-based Knot My Name will display her contemporary artwork at Platform. Using eco-friendly materials, Hecht produces handmade macramé products and made-to-order pieces. Another one to watch at Platform is

Timber Robot Studio – set up by Philip Gay in 2022. A former propmaker from the film industry, Gay retrained in fine woodwork in 2021 before starting his furniture and homeware business. At CDW, he will showcase his latest handmade designs – including an Art Deco-inspired chest made from solid ash and rippled ash veneer.

Meanwhile, over at Detail, interior architects and founders of Ziba Homes, Mitali Bansal and Ria Chhabra, will launch three new pieces of furniture – an exquisite collection of patterns curated using a wide range of materials and handcrafted techniques. One of them is the Emerald Envy malachite console combined with ash wood and wicker – which will be on show alongside a coordinating set of home accessories. Also at Detail is Holmes Bespoke – founded by Laylah Holmes – which will debut its new range of handcrafted rugs and runners exclusively at CDW.

## THE OUTDOORS IS CALLING

Lighter, warmer days are just around the corner – and this year's CDW returns with another exciting line-up of outdoor furniture launches.

A long-term supporter of the festival, Clerkenwell-based Jennifer Newman Studio will have an installation in St John's Square focusing on outdoor terrace products – all made in London – and is set to reintroduce its classic Alfresco bench and Huddle table at the festival. At Detail, Italian company Ethimo will present its 2023 collection including the in-house designed Bold table, as well as a series of concrete vases – named Bulbi – by Studiopepe.

While British company Case Furniture at Groupwork in Clerkenwell Green will display its Eos outdoor collection by Matthew Hilton, its Danish counterpart, Norr11 (Showroom) will launch the new outdoor editions of its popular Studio sofa and Hippo lounge chair at CDW.

Internationally renowned, CDW has long established itself as a major platform for both established and emerging design businesses to showcase their latest innovations and forward-thinking ideas.

“After more than a decade of championing design excellence and launching the career of many young talents, CDW has cemented itself as a global design destination and one of the most important events among the architecture and design community,” says Marlon Cera-Marle, Design Division Director of Media 10.

“We're thrilled to be back with an even bigger line-up, including some of the industry's most dominant figures. From thought-provoking installations to exciting new names and product innovation, we look forward to bringing an abundance of creativity and world-class content to the heart of Clerkenwell this May.”

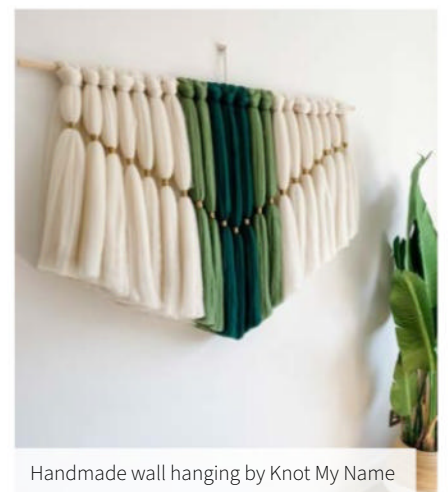

Handmade wall hanging by Knot My Name

The 12th edition of Clerkenwell Design Week takes place across EC1, London from 23 – 25 May 2023. For more information, please visit [clerkenwelldesignweek.com](https://clerkenwelldesignweek.com).

the UK's leading design festival



clerkenwell **23-25**  
design week **may**



**register now**

[clerkenwelldesignweek.com](https://clerkenwelldesignweek.com)

 [cdwFestival](https://twitter.com/cduFestival)

 [clerkenwell.design.week](https://facebook.com/clerkenwell.design.week)

 [clerkenwelldesignweek](https://instagram.com/clerkenwelldesignweek)

[#cdw2023](https://twitter.com/cduFestival)



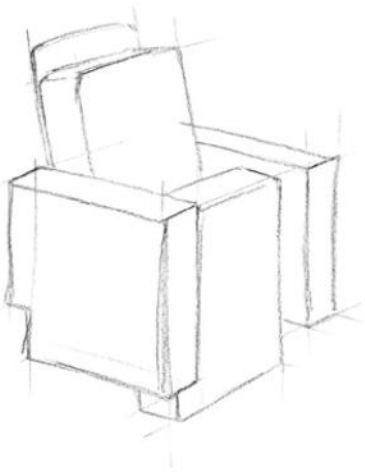

## The Art of Seating

[www.figuerras.com](http://www.figuerras.com) | [hello@figuerras.com](mailto:hello@figuerras.com)

With a passion for design that has driven us since 1929, we create customizable and bespoke seating solutions that reflect a unique style for each project.



# SIMONSWERK SHOWROOM OPENS ITS DOORS **FOR** **CLERKENWELL DESIGN WEEK**

SIMONSWERK will be opening its showroom doors for the return of Clerkenwell Design Week. The three-day event takes part on the 23rd-25th May, showcasing leading UK and international brands and companies in a series of showroom events, exhibitions and special installations that take place across the area.

Visitors to the showroom at 45 Great Sutton Street will be able to view the SIMONSWERK Groups full range of hinge applications including the BILOBA hydraulic hinge concepts for glass doors, the ANSELMI concealed hinges for light residential doors together with the TECTUS heavy duty hinge.

Also on display will be the online advanced PRODUCTSELECTOR information system created specifically for architects, ironmongers, specifiers and interior designers.

SIMONSWERK are Europe's leading Hinge Manufacturer with a history spanning more than 130 years in the manufacture of brass, aluminium and stainless-steel hinges for doors and windows. The range includes the renowned fully concealed TECTUS hinges and the popular TRITECH solid brass hinge with concealed bearings.



**SIMONSWERK Showroom in Clerkenwell**  
**From 23.5. - 25.5. daily from 10 a.m. to 7.00 p.m.**  
**45 Great Sutton Street, London EC1V 0DE.**

Find out more and register for free at [www.clerkenwelldesignweek.com](http://www.clerkenwelldesignweek.com)

Kronodesign®

# NEW GLOBAL COLLECTION

K554 HU Chocolate Hudson Oak

K514 SU Deep Sahara

K516 SU Toffee

K530 HU Amaretto Hudson Oak

K521 SU Smoke Green

K542 FN Mocha Tessea

## A World of Design Possibilities™

Your chance to experience a comprehensive working palette of exclusive decors perfectly curated to satisfy the needs of the most creative and innovative architects and designers.

178 DECORS  
New Level of Realism  
Sustainable Manufacturing  
Creativity at your fingertips

clerkenwell 23-25  
design week may  
PC2 Come and see us in projects



[www.kronospan.co.uk](http://www.kronospan.co.uk)

kronospan

# COLOUR, IT'S IN OUR NATURE



Biophilic design and sustainability are red hot topics. The trend in green architecture has definitely done a great job of decreasing the environmental impact of the built environment. So much so that green walls, pot plants and wood have now become a shorthand for biophilic, nature-led design.

But it's so much more than that.

What we've been seeing as 'green architecture' is just one expression of nature, and one of a range of nature-based ways we can express ourselves.

Why just limit ourselves to green when we have nature's colour palettes at our disposal?

## **Back to nature is the future of design**

Most humans love being in nature. It's why we sit in the park at lunch, go for a walk in the woods, or swim in the sea when we get the chance. We have a subconscious connection to it and innately know that nature restores, grounds and supports us.

But with so many of us now living in high-density urban environments, we can really miss that connection.

That's why nature-led design is so powerful. It allows us to create this connection to nature by using harmonious colour combinations, textures, patterns, and shapes that reflect that subtle experience of being in nature.

The best part is that nature has already provided everything we need with colour palettes and designs that resonate with our personality and help us to feel that sense of familiarity that we do when out in nature.

Because when we use nature's colour palettes and designs in their purest form, we are surrounded by harmony and balance. When we don't use them as nature intended, that's when we can feel uncomfortable in a space because something feels 'off' or jarring.

As our society evolves to include even more technology, AI and denser urban living, it will become more important than ever before to bring that connection to nature into the built environment.

This is how we can support people now, and into the future, to feel safe, secure and thrive in the balance between modern living and what it is to be human.

And we can lead the way by putting humans at the centre of our designs and by using colour consciously to create spaces, places and environments that are good for the individual, for others and the planet.

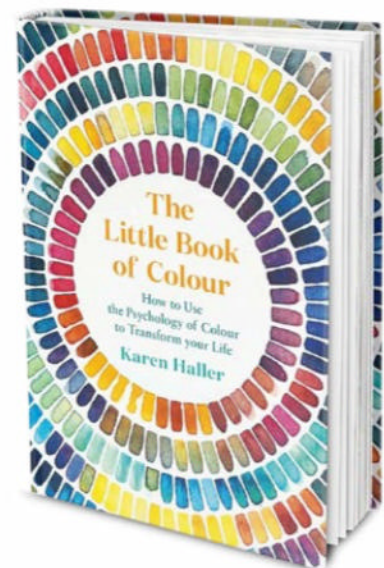

To find out more how to use colour consciously for nature-led design, go to [karenhaller.com/free-10-myths-ebook](https://karenhaller.com/free-10-myths-ebook)

Email: [karen@karenhaller.co.uk](mailto:karen@karenhaller.co.uk) | Website: [Karenhaller.com](https://karenhaller.com)

# Now, It's Your Turn

Explore the world of space-saving furniture



Our range of rotating and sliding products

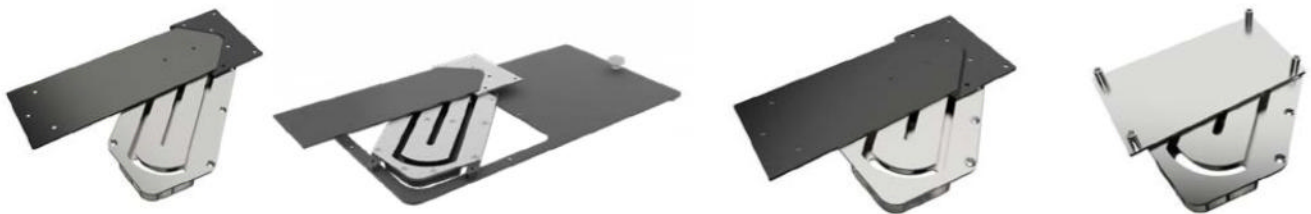

# THE ART OF SOPHISTICATION

Domin Design has recently completed a stunning interior design project in the dining room of a luxurious villa in Nicosia, Cyprus.



The goal was to create a sophisticated and elegant space that would inspire a sense of grandeur and refinement. To accomplish this, Domin Design incorporated a range of exquisite lighting fixtures from Castro Lighting, such as the Mastery Wall Light, the Twist Suspension, and the Twist Wall Light.

The Mastery Wall Light is an exceptional piece that illuminates the room with a soft and warm glow. Its unique design was inspired by the book *Mastery* by Robert Greene. The delicacy of the different-sized pieces and the finishes used led to the name of this design, reminding the traits and universal ingredients that made the characters of the book masters. The soft curves of this lighting fixture add a touch of fluidity to the space, making it feel more organic and dynamic. This handmade wall sconce can be customized as you prefer to create the perfect bespoke combination for each unique interior design project.

The Twist Suspension is another remarkable lighting fixture that Domin Design chose to incorporate into the dining room's design. This pendant light features an intricate design of twisted metal, which gives it a sense of movement and energy. The Twist Suspension hangs low above the dining table, casting a warm and inviting glow that creates an intimate and cosy atmosphere.

Last but not least, the Twist Wall Light adds a finishing touch to the dining room's design. This elegant sconce features the same twisted metal design as the Twist Suspension, creating a cohesive and harmonious look. The Twist Wall Light also adds a sense of depth to the room, casting a subtle shadow that accentuates the room's architectural features.





Together, these three lighting fixtures create a sense of elegance and luxury in the dining room of this sumptuous Villa in Nicosia, Cyprus. Domin Design's implementation of these exquisite fixtures demonstrates its expertise in selecting the perfect lighting elements to create a stunning interior design.

The Mastery Wall Light, the Twist Suspension, and the Twist Wall Light come together to create a masterpiece that is both stylish and functional, enhancing the dining experience for the villa's habitants and guests alike.

[www.castrolighting.com](http://www.castrolighting.com)

**CREDITS: Domin Design**







Deirdre Dyson®

EXCLUSIVE CARPETS AND RUGS

ANGLES Collection 2023 – Can-Can & Clarity

[www.deirdredyson.com](http://www.deirdredyson.com)

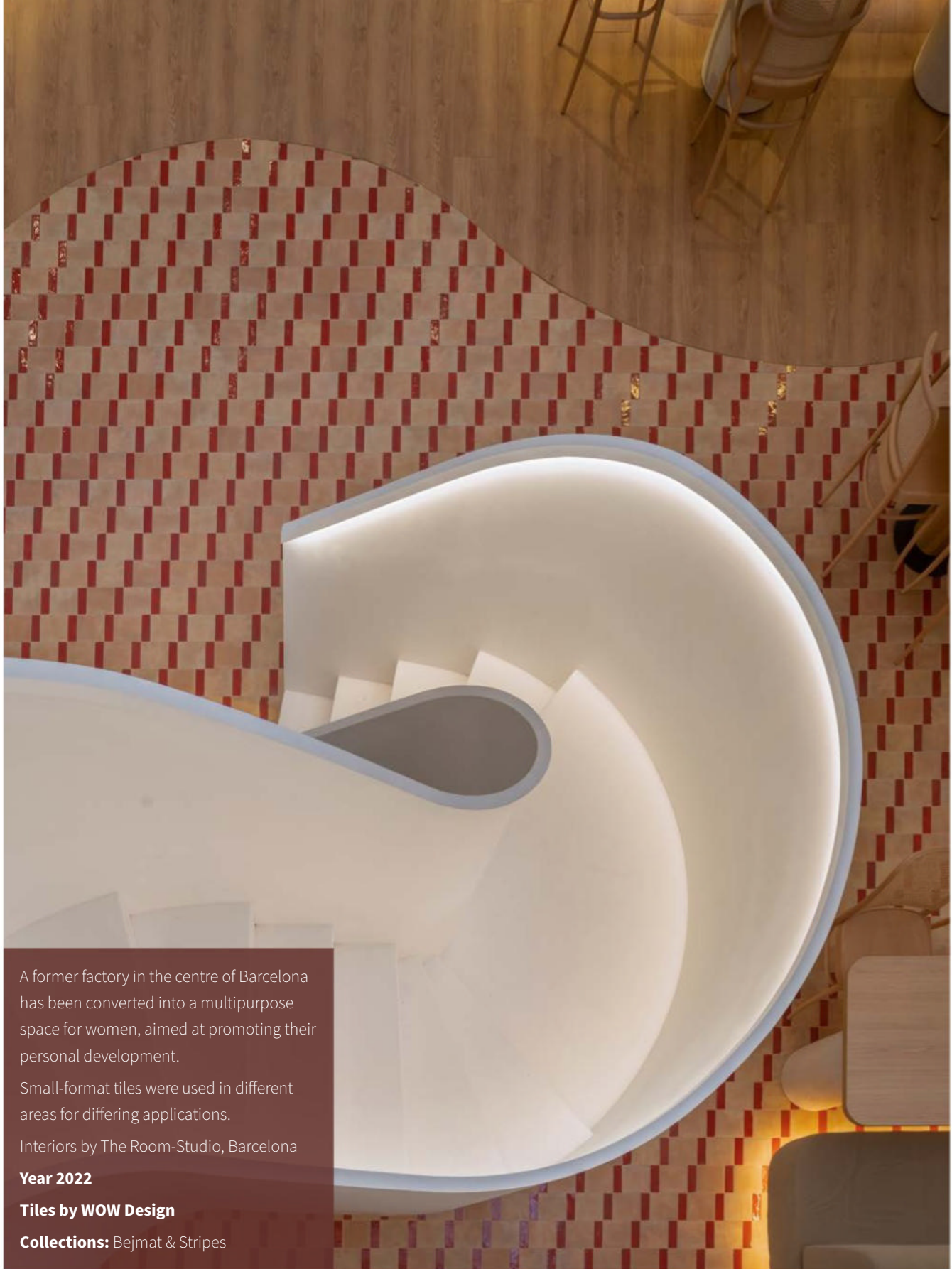

A former factory in the centre of Barcelona has been converted into a multipurpose space for women, aimed at promoting their personal development.

Small-format tiles were used in different areas for differing applications.

Interiors by The Room-Studio, Barcelona

**Year 2022**

**Tiles by WOW Design**

**Collections:** Bejmat & Stripes

# TILES BY WOW DESIGN AT JUNO HOUSE, **THE FIRST WOMEN'S CLUB IN SPAIN**

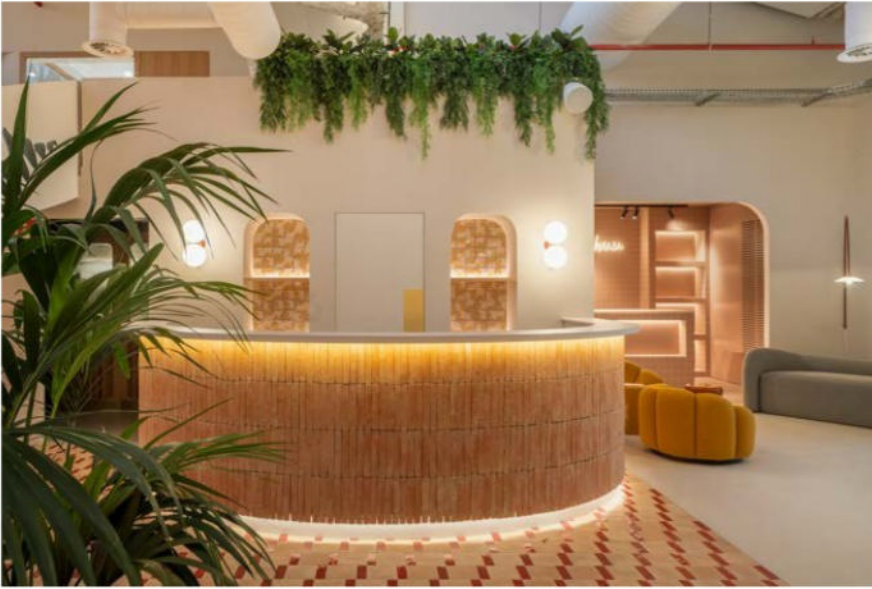

Juno House stands in Barcelona's business centre. It is the first social club in Spain designed to meet contemporary female needs, founded by a group of Spanish and North-American women. This unique design project was carried out by the team at The Room-Studio, with the collaboration of WOW Design whose signature tiles feature in several of its areas.

## A FORMER FACTORY IN THE HEART OF BARCELONA

The focus of this design project is La Farinera, a 19th century former factory covering an area of over 1,400 square metres, made up of a five-storey tower and big industrial warehouse.

The interiors of this architectural gem, hidden away in the heart of Barcelona, were renovated by The Room-Studio in order to create a new concept of a women's social club, aimed at fostering their personal and professional development.

Juno House is a multipurpose space, with a refreshing Mediterranean design based on a use of natural materials, bespoke items specially designed for the club, and varying



interconnected areas. Tiles by Wow Design feature prominently in some of these spaces.

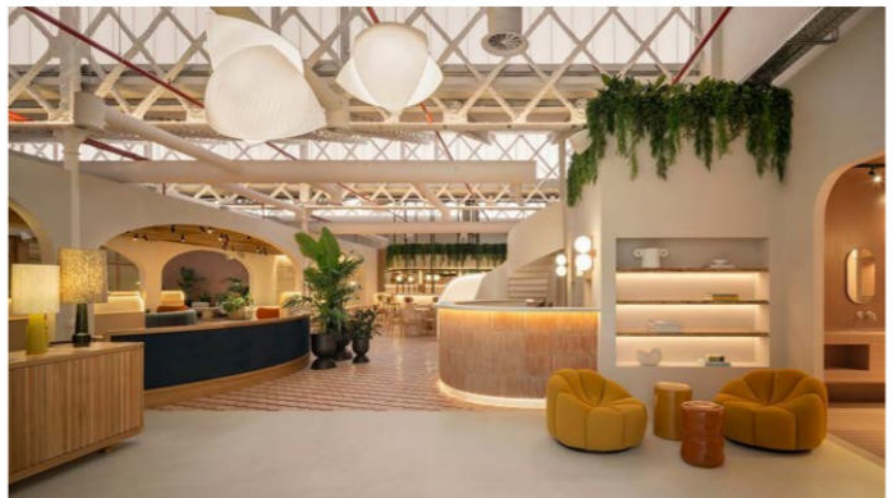

This concept of a club, designed to meet very specific needs, could not be found in Spain up until now. Its facilities include a restaurant, shop, meeting rooms, stage, recording studios, crèche, offices, library, exhibition room, chill-out zone, sports areas, wellness and beauty centre, and numerous leisure areas.

## A BIG CERAMIC RUG IN THE SIGNATURE RESTAURANT

The spacious restaurant, specializing in signature cuisine, is one of the main focal points of the complex, with floor tiles from the Bejmat collection by WOW Design in the form of a big ceramic rug. The mix of red glazed tiles and terracotta-coloured ones affords just the right contrast and touch of warmth. With their different format, texture and shine, the tiles give the restaurant an upbeat appearance, infusing it with all the appeal of natural materials.

The area behind the restaurant bar is clad in rectangular relief tiles, laid vertically to lend the surface a certain sense of movement. The tiles are from the Stripes collection, also by WOW Design.

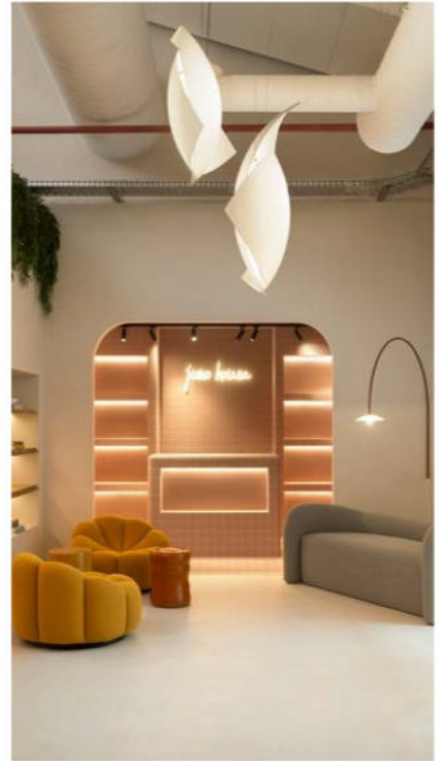

## A HIGHLY MEDITERRANEAN DESIGN PROJECT IN EARTHY SHADES

For the design team, “Juno House had to be strongly identified with Barcelona, looking back at the past a little and reviving traditional crafts”. Ceramic tiles were used “because the club had many organic features and we wanted to take advantage of different textures,” they added.

“We were looking for earthy shades in order to give the project a natural appeal, so we opted for tiles in both a natural and a glazed finish so as to ensure a restful, organic appearance,” said Meritxell Ribé, The Room-Studio’ interior designer.

## GLOBAL SOLUTIONS BY THE ROOM-STUDIO

The Room-Studio is an interior design and architects’ studio headed by Meritxell Ribé and Josep Puigdomènech. It focuses on capturing the essence of different spaces and expressing it through sensory experiences. Thanks to the studio’s 20 years’ experience and its multidisciplinary team of staff, it is able to specialize in global solutions.



[wowdesigneu.com](http://wowdesigneu.com)

**mavi**  
ceramica



[www.maviceramica.it](http://www.maviceramica.it)

# THE RAISE BOOKCASE BY TOMASELLA: **A JOURNEY THROUGH TIME AND DESIGN**



Tomasella is presenting its new Raise bookcase.

Raise is a versatile project studied to adapt to all the requirements of everyday life and to satisfy the new lifestyle changes that put more and more focus on the reception room bookcase.

The Tomasella company has developed this dynamic model whose functions evolve while preserving its elegant appearance. Thanks to the possibility of adding a desk to its structure, Raise can even become a space to work or study in. A home office corner that fits in perfectly with the rest of the living room area can be easily created by just adding a seat.

The new Tomasella bookcase features a minimalist design that is inspired by the 70s but has a contemporary and modern twist.

Shelves, modules with doors and drawers – perfect for hiding away all those items you don't want to showcase – are secured to the wall structure and make the bookcase even more functional and tidy. The shelves on Raise feature a black edge that lends a unique touch to this model by exposing and enhancing the core of the panel, just like the objects and books displayed on it.

With its new bookcase, Tomasella perfectly represents the way people currently use the home.

Raise is available in many finishes and sizes.

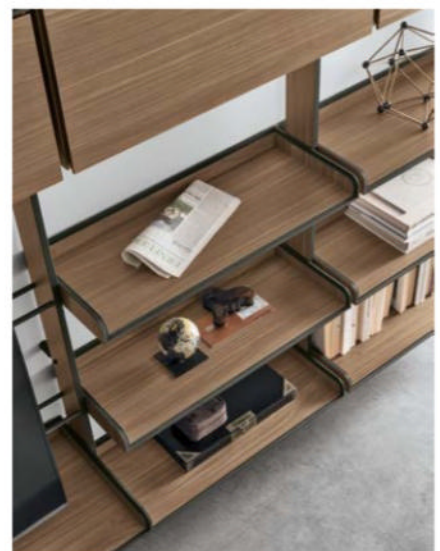

[info@tomasella.it](mailto:info@tomasella.it) | [www.tomasella.it](http://www.tomasella.it)

AFFORDABLE LUXURY



[my-furniture.com](http://my-furniture.com)

enquiries: 0800 092 1636



Prima

# NEXT STOP: COVERINGS

The range of Caesar porcelain stoneware solutions expands, presenting new Made in Italy and Made in the USA products at Coverings.

On the eve of one of the most important events for the natural stone and ceramic sectors, Caesar announces the introduction of some new products to its Made in Italy and Made in the USA ranges, thus expanding the offer of furnishing solutions according to the most varied international trends.

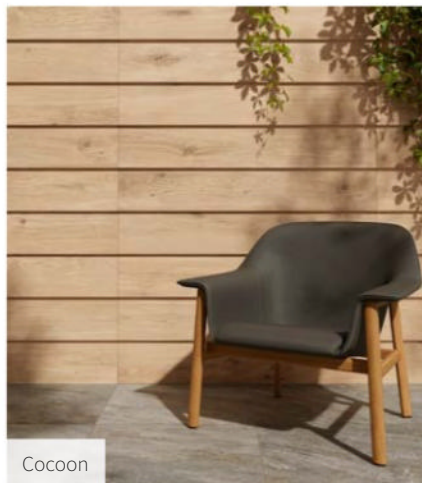

Cocoon

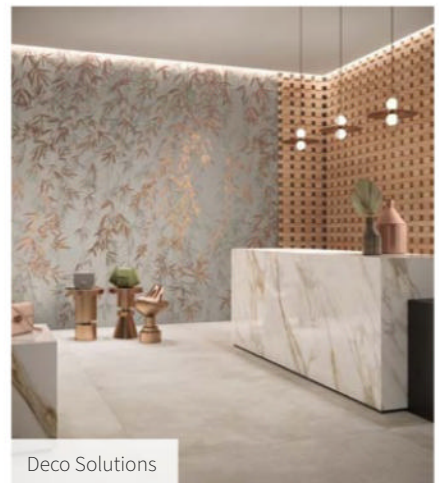

Deco Solutions



At Coverings - staged at the Orange County Convention Center in Orlando (FL) from 18 to 21 April - the Fiorano Modenese company will unveil the new flagships of a proposal that had already broadened its horizons at Cersaie.

## BRAND NEW AND TOP PRODUCTS WILL INTERACT IN A LEADING TREND SETTING.

These include a new Made in Italy and two new Made in the USA collections, in addition to the Caesar collections already displayed at the Bologna exhibition: Prima - a reminder of the essentiality of clay revisited with a captivating contemporary accent - Cocoon - a ceramic reproduction of the finest wood, to dress the home and other architectural spaces with warm and enveloping atmospheres - and Deco Solutions - a wide range of decorations in which textures, colours and modular designs allow all projects to be characterised with style - These will be recalled by the iconic Made in the USA collections, distributed as stages in a journey through different furnishing solutions.



Prima



Cocoon

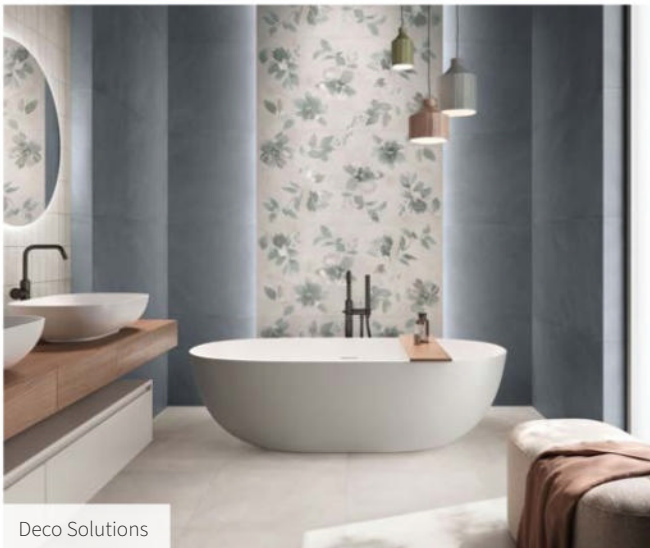

Deco Solutions



Booth 1515 will also feature Caesar's different outdoor declinations, encapsulated in the bivalent Made in Italy and Made in the USA soul of Aextra20. Created to take outdoor design to the pinnacle of technical and aesthetic performance, Aextra20 greatly expands the horizons of outdoor design and offers the ideal answer for those looking for wide-ranging solutions for gardens, swimming pools or commercial premises.

# ISLA POPS OF COLOUR



Elstead Lighting will launch their new 2023/24 Master Catalogue in June which will include over 100 new products which were showcased at EuroLuce. Featured is the Isla Table Lamp Collection.



Elstead hand crafts many shades for portable, wall and ceiling fixtures in their UK factory. If you have a project that requires a particular colour we would be delighted to make bespoke options for you. We welcome you to visit the Elstead Showroom in Alton, (GU34 2QJ). It is one of the largest lighting showrooms in the UK where you will see more than 3000 products on display.

This new range has 8 different shades of 2023 trending colours. Four will be paired with aged brass metalwork and another four with polished nickel, all presented on a simple white ceramic table lamp base, so that the bright and cheerful shade colours pop.

For those who are more daring look out for eight bold patterned shades available in the new Milo range.

If you prefer the beauty of glass, then explore the options of Samara and Milne table lamps from Elstead's Quintiesse Collection. These beautiful hand-blown glass bases are lit with a secondary lamp source to make the glass shimmer when lit. They come complete with hand-crafted shades made in Elstead's UK factory, with several colours of glass or shade options to choose from.



 **Elstead**  
LIGHTING

To see our extensive range of decorative lighting download the Quintiesse and Elstead catalogues from our website [www.elsteadlighting.com](http://www.elsteadlighting.com) or request printed copies to be sent to your design office/studio by emailing: [enquiries@elsteadlighting.com](mailto:enquiries@elsteadlighting.com)



**QN**  
QUINTIESSE

## DESIGN BROUGHT TO LIGHT

Lena Table lamp. 2 sizes, 3 beautiful colours featuring dual-lit lighting to make the mouth-blown glass delightfully shimmer. Made in the UK.

 **Elstead**  
LIGHTING

+44 (0)1420 82377 | [enquiries@elsteadlighting.com](mailto:enquiries@elsteadlighting.com) | [www.elsteadlighting.com](http://www.elsteadlighting.com)

# SHINING A SPOTLIGHT ON DESIGN



Catalogue 26 and Supplement offers hundreds of ranges that cater for both contemporary and classic design styles. However launched earlier this year in sneak product preview is the Galaxy, a comprehensive range of single and multiple suspensions in satin nickel with clear cable or aged brass with black cable. Available with a choice of clear, amber, smoked or matt opal glass spheres in various sizes.

The Cosmic range offers a choice of satin nickel or antique gold finish fittings. Available with a selection of matt opal, amber or smoked glass spheres. Featuring 9 and 12 light pendants that convert to flush fittings for areas with lower ceilings or single and two light wall brackets that are ideal for hallways and bedside lighting, this range is perfect for home interiors.

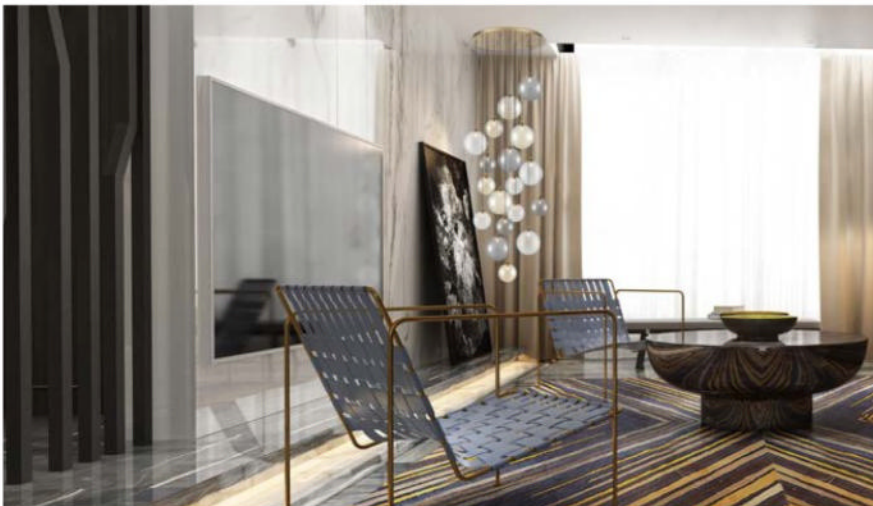

Franklite celebrates its 50th anniversary this year by introducing two new product ranges. Over the years Franklite has manufactured exquisite products for the retail, residential, commercial and hospitality markets including bespoke product designs.

With bubble lighting on trend for 2023 the Galaxy and Cosmic ranges could not have been introduced at the more perfect time. Bubble lighting is globe or sphere shaped lights and this round compact design will never go out of style.

For more product ranges suitable for luxury residential interiors contact our Customer Service team on **+44(0)1908 691818** or visit our website on **[www.franklite.co.uk](http://www.franklite.co.uk)**



**franklite**  
shining a spotlight on design



**decorative lighting solutions** | commercial | retail | hospitality | project designs

[www.franklite.co.uk](http://www.franklite.co.uk) · [info@franklite.co.uk](mailto:info@franklite.co.uk) · +44 (0)1908 691 818 ·



# THE READING REVOLUTION FROM DAYLIGHT™



Established innovative UK Lighting brand, Daylight™ specialise in developing innovative and quality task lamps for the home and professional sectors. Premium quality begins with their in-house product design team with over 30 years of accumulated industry experience creating elegant and ergonomic lamps.

## CARE FOR YOUR EYES AND QUALITY OF LIGHT

Unlike other brands, Daylight™ lamps reproduce natural light so you can see clearly at any time of day or night. With their exceptional technology and ergonomic design, Daylight™ brings the latest innovation to your space. Their in-house design team create new products to enable individuals to see better, no matter what task they are doing. Whether you are reading, working, crafting or simply relaxing, Daylight™ technology guarantees a controlled bright light with high levels of contrast and perfect colour-matching.

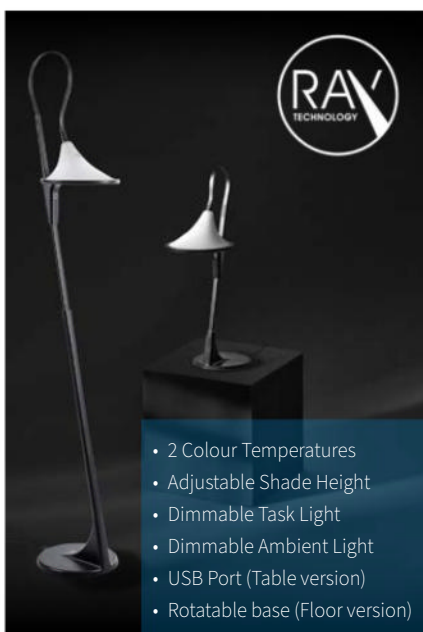

- 2 Colour Temperatures
- Adjustable Shade Height
- Dimmable Task Light
- Dimmable Ambient Light
- USB Port (Table version)
- Rotatable base (Floor version)

An inspiring new arrival, the **Cometa™** Table and Floor lamps are expertly designed with innovative **Ray Technology™**. The **Cometa™** throws light forward and eliminates glare, as well as providing a warm ambient light to relax.

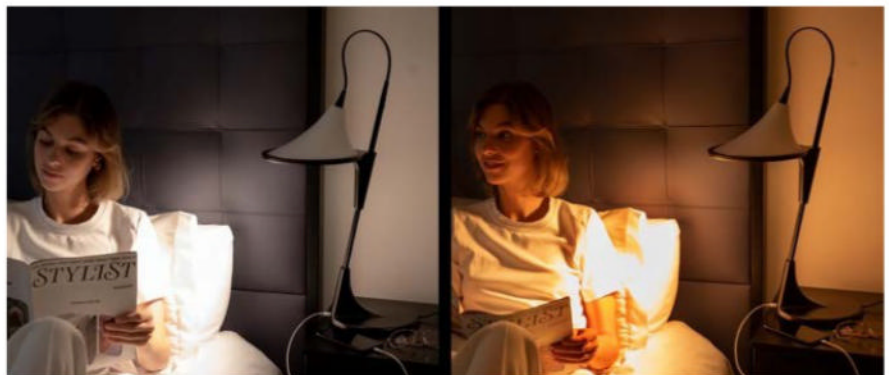

Discover more about Daylight™ lamps at [daylightcompany.com](http://daylightcompany.com)



# Cometa™

FLOOR LAMP





# EXCLUSIVE DISTRIBUTORS AND SALES AGENTS FOR HIGH QUALITY LIGHTING MANUFACTURERS

Established in 2008 Clifton lighting are exclusive agents and distributors for a number of high end European lighting companies, offering unique, innovative, high quality products to the UK along with first class high quality service.

Each year we source carefully selected new high quality companies handpicked from Europe that we are proud to be able to sell and represent here in the UK.

With our extensive knowledge and experience of the European market we present unique designer ranges with the ability to design and manufacture bespoke products, bringing complete lighting solutions to every project.

We are able offer lighting solutions for both indoor and outdoor projects, whatever the requirement, be it classic timeless style or the latest cutting-edge technology, our partners use only the highest quality components whilst keeping up with current trends and maintaining timeless classic designs.



The lighting industry has a very important role to play in the sustainability of our planet which is very important to us here at Clifton Lighting, our partners and ranges offer recyclable lighting with replaceable components, recycled materials, and packaging steering us towards a better, more sustainable future. We are part of the Recolight

recycling scheme ensuring all the lights we supply are compliant with the latest Environment Agency guidelines for a sustainable future. Changing to LED has never been so easy and can pay dividends for the budget and for the planet.

[www.cliftonlighting.co.uk](http://www.cliftonlighting.co.uk)





# EBB & FLOW

Room for personality

[www.ebbandflow.com](http://www.ebbandflow.com)

*See Ebb & Flow at Catapult venue, Stand CP14, Clerkenwell Design week 23-25 May 2023*

Clifton Lighting are UK sales agents for Ebb & Flow, please contact us for further information.

Tel: 01484 712 097 | Email: [sales@cliftonlighting.co.uk](mailto:sales@cliftonlighting.co.uk)

[www.cliftonlighting.co.uk](http://www.cliftonlighting.co.uk)

# BLOOMSBURY MANSION APARTMENT, LONDON - LLI DESIGN



LLI Design were commissioned to completely redesign and refurbish a period apartment in a grand mansion block in the heart of Bloomsbury London.

Situated in the historic heartland of the west end and close to the theatres of Covent Garden this 2 bedroom apartment hadn't been renovated in many years so was in effect a blank canvas to create a beautiful pied a terre for the clients.

The brief was to keep and enhance the period details of the apartment, incorporating the clients' inherited furniture pieces and combining them with new contemporary pieces to create an eclectic mix that suited the clients aesthetic.

## Existing Layout

The layout of the existing apartment was based around a long central corridor with rooms on either side.

All rooms enjoyed high ceilings, original cornices, skirtings, architraves; and generously proportioned windows. The central corridor that joined all the rooms, although in the centre of the apartment, had the benefit of borrowed light via fan lights above most of the room doors.

The two bathrooms were typically proportioned for an Edwardian mansion flat and were small and relatively dark.

On the north side of the apartment there were two reception rooms and a bedroom. On the south side of the apartment there was a further reception room, the kitchen, and another bedroom. On the west side of the apartment there were two bathrooms.



The rooms on the north side of the apartment overlooked the central courtyard of the grand mansion block, with the nearest adjacent tall building circa 5 metres away. The rooms on the south side of the apartment had views towards the city with the nearest adjacent tall structure some distance away. The effect of this is that

there was a stark contrast in natural light levels between the north and south side of the apartment.

## Revised Layout

To make the apartment work for the clients and to maximise all the space available it was decided to amend the layout as



follows. The two reception rooms on the north facing courtyard side would be knocked through into one to create a generous open plan library / dining room. By combining these two rooms into one larger space it created a more cohesive feel to the apartment as a whole.

The light filled southside reception room would become a music room, with a baby grand piano as its centrepiece.

It was decided that the bedroom on the south side would become the master bedroom, it had the advantage of a beautiful, tall tree outside the window, unusual for a 5th floor apartment. The other bedroom on the north side would become the guest bedroom.

The kitchen would remain largely in its original position, albeit completely reconfigured and re-designed to incorporate a small island and a hidden utility area and a larder space.

The position of the kitchen door was moved, so that it would be accessed via the central corridor rather than a small dog leg off the corridor as it was before. The remaining dog leg was incorporated into the new master bedroom.

The guest bedroom remained in its existing position as did the family bathroom.

A small coats cupboard accessed from the central corridor was created from part of the library.

For the majority of the spaces wide plank timber flooring in a warm pale grey tone was specified to visually tie the spaces together. The bedrooms were carpeted in a deep pile soft grey carpet and the bathrooms were tiled, which was complimented with underfloor heating.

The lighting design for the apartment was challenging as the construction of the ceilings didn't allow for any recessed lighting so all luminaires had to be surface mounted or incorporated in joinery.

#### **Central Corridor**

The entrance to the apartment needed to feel warm and welcoming with no clutter. The original layout made no provision for a coats cupboard. As the corridor was quite narrow it couldn't easily accommodate a joinery cupboard, instead it was decided to 'nibble' a small amount out of the generous library room adjacent to the hall in order to create storage for coats, shoes, suitcases etc.

In order that the strong lines of the corridor were maintained and that the cupboard was as unobtrusive as possible a 'invisible' door was created, with no architrave and with the skirting detail included in the door

design, so that the whole wall read as one.

The high ceilings throughout the property were emphasised with a tonal colour scheme in half tones of grey picking out coving and skirting details. Large dramatic pendant lamps were specified all the way down the corridor to emphasise its length, with a large round mirror and a console shelf creating a visual full stop at the end.

#### **Library**

The two reception rooms on the north side of the property were integrated into one, to create a new library room / dining room. This helped natural light flow from one room to the other and brought a light airy feel to otherwise quite dark spaces.

Part of the brief was to install a working fireplace to make the space feel warm and cosy, but because of the confines of the apartment block it was not practical to install a gas fire and associated flue / chimney, however a fire surround was designed and integrated into the new bespoke joinery unit and a cast iron, realistic faux log burner was installed in the new fireplace surround, bringing a sense of cosiness to the space.

A small portion of the existing room which formed the library was partitioned off to create the cloak room in the central corridor, this created a small return in the

library, but this wasn't visually intrusive as the coving, skirting and dado detail wrapped seamlessly around the new return. The new return was then integrated into the bespoke joinery bookcase that was designed along the back wall thus making the whole amendment feel natural and virtually invisible.

A large TV was integrated into an alcove above the fireplace, so that the TV sat flush and did not dominate the space. The bespoke joinery unit along one wall provided a much needed display space for objects, books and collectables, and feature wall lights with brass details completed the joinery unit.

A simple classic style sofa with a chaise end was added to complement the clients' collection of antique furniture and rugs.

Once again period details were picked out in half tones of pale greys to give a warm and calm feel to the space. By combining these two rooms and with careful consideration and specification of furniture, joinery and the material palette, London interior designers LLI Design, completely transformed these spaces.

### **Kitchen**

The kitchen benefitted from a window with views of the beautiful, tall tree outside, which it shared with the master bedroom. For the kitchen a fresh, bold and invigorating colour palette was selected, pale lilac lacquer, palest dove grey, and gold details with bleached wooden shelving created a fresh and bright modern kitchen with plenty of visual interest.

The bespoke joinery kitchen layout featured a centre island with a pale grey composite worktop and a dramatic gold pendant light. Traditional shaker style kitchen units, some featuring glass fronts to showcase glassware added to the visual interest. Cabinetry featured gold cup pull handles and knobs, which helped give the kitchen a contemporary feel.



The same warm toned wide plank floor as the rest of the apartment continued into the kitchen; this was repeated in the underlit wooden open shelves for plants and books. Glazed porcelain artisan metro tiles in soft tones with a pale grey border created the backsplash.

A tall lilac lacquer unit disguised a small but very practical utility area. The washer / dryer was placed at high level with a pull out drawer below for laundry and shelves above for linen storage.

The original opening for the fireplace range was repurposed to create a larder unit with pull out wicker baskets.

### **Dining Room**

The furniture in the dining room consisted of the clients' much loved inherited pieces that were renovated, restored and french polished bringing them back to their former glory.

As a contrast to the period furniture the space was contemporised by a large contemporary, brass pendant light with exposed squirrel cage lamps to sit above the dining table. An opulent, oversized, gilt framed wall mirror bounced light into the room. Bespoke joinery alcoves were positioned either side of the chimney breast making the most of all available space. The clients' richly patterned persian carpet helped pull all the visual elements together.



## Music Room

The music room was designed as a bold and dynamic space, bright colours and patterns offset the drama of the polished black baby grand piano that was the centrepiece.

To balance the visual presence of the piano an extra large wooden framed mirror was installed on one wall and a classically styled chaise lounge added an air of decadence.

A bold statement multi coloured Missoni chevron rug and dramatic mid blue bespoke joinery unit with brass wall lights above completed the room.

## Master Bedroom & Ensuite

A soft romantic feel for the master bedroom suite was created with a palette of bruised pinks, greys and taupes, with a mix of tactile fabrics to create a decadent mood. The french styled bed in a natural coloured grey linen with a bleached wooden frame, complemented the elegant classically styled bleached out bedside tables, which had staggered height vintage ribbed globe pendant lights above them. A large vintage metal distressed chandelier was sited above the bed.

A bespoke full height joinery wardrobe in taupe satin lacquer along one wall, hid drawers and hanging. A gentle and very subtle texture wall covering was specified to enhance the feeling of calmness, and opulence.

## Family Bathroom

Although small, the family bathroom benefitted from unusually high ceilings and had the benefit of a window, allowing natural light into the space. A simple, light palette of soft whites and carrera marble effect porcelain tiles were selected to make the space feel as big and a light filled as possible.

To add character to this small space, new ceiling coving and picture rails which matched details found elsewhere in the property were specified, this helped to bring



a period feel to the whole and emphasise the rooms height, whilst also adding texture and visual interest. A simple ribbed globe pendant added accent lighting.

Storage was created by way of a bespoke white lacquered cabinet above the WC, a mirror cabinet above the basin and the vanity unit itself provided a large storage area.

## Guest Bedroom

The classical bow-fronted richly coloured walnut chest of drawers inherited by the clients' was the starting point for this room. This was emphasised by a classical gold gilt mirror above and a wall of panelled lacquer wardrobes along one wall. The upholstered bed in blue linen, and the contemporary styled foxed mirror bedside table gave this room a warm and welcoming feel.

## Lighting Design

The lighting design for the apartment was challenging as the ceilings were concrete, which meant that no recessed lighting could be installed, accordingly all ceiling light was provided by a minimalist architectural track lighting system, this supported the feature lighting which was incorporated by way of pendants, and joinery lighting.

## Summary

By way of reconfiguration, clever use of colour and lighting together with bespoke joinery elements throughout, this property was completely transformed from a dark tired apartment into a light filled pied a terre for our clients.

It was essential that the apartment kept its character and atmosphere and by taking an holistic and sensitive approach to the design and layout LLI Design created a warm, friendly and practical apartment for the clients whilst staying true to the character of this grand mansion block.

As with the majority of LLI Design's projects, the construction, joinery and home automation were carried out by our in-house vertically integrated teams - Pegasus Property & Pegasus Automation.

# SMART CHOICES **FOR SMART HOMES**

Consumers have an increasing understanding of what the smart home should be able to provide, and their vision is holistic. They look for appliances that can be operated by voice command or via an App and which react automatically to environmental conditions to provide a customised solution in terms of space, air quality, lighting architecture and energy efficiency. Consumers expect products that combine an aesthetically pleasing appearance with a comfortable and healthy environment.

ILLUSION Plus and SKYDOME Plus from Elica are the first ceiling hoods to incorporate Wifi control and automatic sensors to monitor and regulate air quality all day long. ILLUSION is the ultimate discrete Hood that almost disappears into the ceiling with its variety of finishes including a fully customisable option whilst SKYDOME conceals its powerful, near silent extraction system behind a 28-watt full LED panel that guarantees uniform light that can be adjusted for both brightness and temperature.

To enable these features Plus models incorporate Elica's Airmatic sensor that can monitor the quality of air continuously during and after cooking. The sensor detects unpleasant odours and cooking vapours and also pollutants like cleaning solvents, cigarette smoke and all the volatile organic compounds (VOC) that are in the air. It automatically adjusts air extraction. When air quality has returned to an optimal level, the product switches off by itself avoiding any energy waste. This advanced technology allows you to obtain the best balance between simplicity of use, energy efficiency and noise. While cooking or throughout the day, the hood sets the most appropriate extraction power.



Wi-Fi and Wi-Fi P2P connection technology enables control via Amazon Alexa or the Elica Connect App with or without wi-fi connection as well as by the Elica remote control. Both new Plus models can be monitored via the Elica App. The hood sends real time status information to the App as well as alerts when the filter efficiency level goes below the minimum threshold.

The light in the kitchen, as in any room, is a key design feature for improving the home living experience. Achieving the right intensity becomes fundamental in creating the desired atmosphere. The Dim Light and Tune white functions enable you to adjust light brightness and regulate the colour temperature, from cool to warm (5000k to 2400k).

Lighting at home cannot be static, so we need different tones of light: a cold light

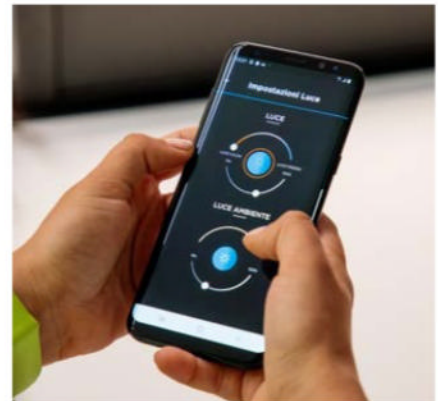

is optimal for cooking, just as a warm one recreates a more relaxed mood. With Tune White you can adjust the LED's colour from warm white to cool white and align the colour of the light coming from the hood with the rest of the lights in the room, for a uniform atmosphere throughout the room.

[elica.co.uk](http://elica.co.uk)



# SKYDOME PLUS CARE FROM ABOVE

## ELICA CONNECT

THE CEILING HOOD THAT PURIFIES THE AIR AND GENTLY ILLUMINATES THE ROOM.

The new Skydome Plus automatically switches on when needed to remove cooking odours, pollutants and allergens but stays off when the air is clean to save energy and help our planet. Extraction speed, lighting brightness and tone can be adjusted by voice or the Elica Connect App. With high performance, almost total silence and perfect ambient lighting, Skydome Plus is a star for your home.

design Fabrizio Crisà

Discover all the advantages on [elica.co.uk](https://elica.co.uk)



 **elica**  
aria nuova

# THE BEAUTY OF BESPOKE JOINERY

## EXPERT INSIGHT FROM AFLUX DESIGNS



From hallways to living rooms, bedrooms to bathrooms, storage is an essential factor in every home – with many homeowners often not making the most of the space available to them. While furniture can provide an effective storage solution, bespoke joinery is made-to-measure, resulting in a range of benefits from maximising space to allowing total individuality.

Amit Malhotra, Co-Founder of Aflux Designs, shares his insights into why joinery is the ultimate storage must-have:

### MAXIMUM STORAGE SPACE

“Custom-made storage is certainly the most effective solution for maximising the space in your home. If you have tall ceilings for example, fitted shelves or wardrobes will ensure every nook and cranny is optimised and suited to your requirements and specifications – something which ready-

made furniture won't necessarily be able to provide. You can then choose how many shelves or drawers you need, the colour and the design, ensuring it pairs beautifully with the rest of your décor.”

### COLOUR COORDINATION

“The beauty of bespoke joinery is that it can be installed at any time – whether it's part of your original design process or you choose to add it at later stage – and colour coordinating is a popular choice

among our clients. Storage can provide a beautiful backdrop when designed well, so opt for your shelves or cupboards doors to be painted the same colour as your walls, resulting in a seamless and cohesive finish.”

### CREATE A STATEMENT WALL

“Alternatively, while many like their storage to blend into the background, bespoke shelving is a great opportunity to create an interesting statement in a space. Paint your shelving a different colour to the rest



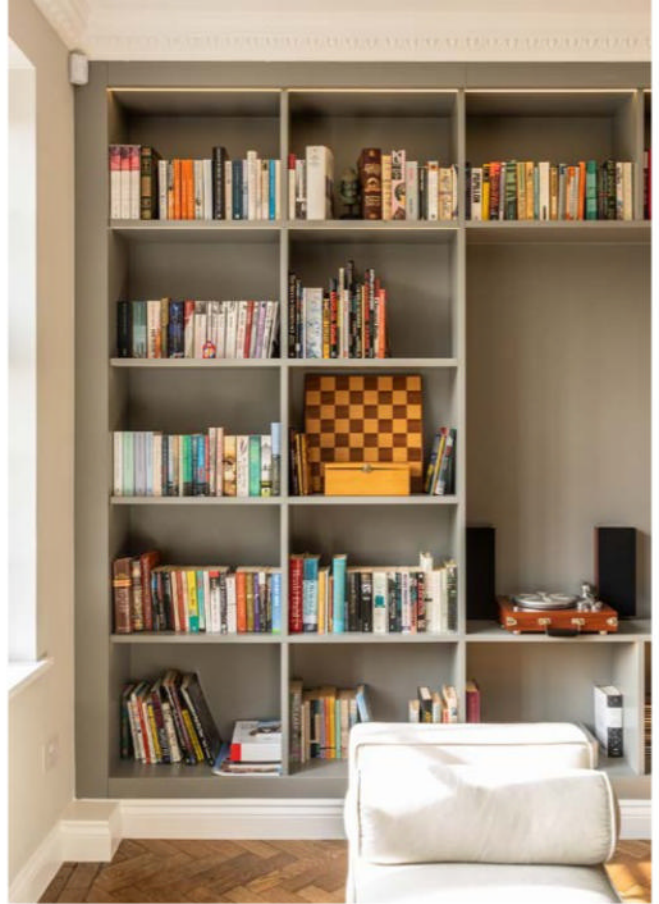

of your walls to create a focal point for your personal possessions and draw the eye in. Add further detail and texture by choosing an interesting wallpaper and applying it to the back of the shelves.”

## INDIVIDUALITY MEETS FUNCTIONALITY

“Bespoke joinery is not only functional and adds incredible value to your home, but it also allows an opportunity for complete individuality and uniqueness. As joinery can be totally customised to you, it is specifically designed to fit your home and your aesthetic so whether you want traditional panelling or modern

floating shelves, a good joiner can help you create a beautiful space that is practical and aesthetically striking.”

Combining 17 years of experience, Aflux Designs prides itself on affordable luxury and is a one-stop-shop that helps homeowners and businesses coordinate their projects from start to finish, with the aim to create an easy journey for every customer.

[www.aflux.co.uk](http://www.aflux.co.uk)

# BESPOKE PREMIUM GLASS SHOWER SCREENS AND ENCLOSURES **FROM MAJESTIC**



The Majestic Shower Company has been leading the way in glass shower screens and enclosures since 1968.

More than 50 years later, the Company's commitment to elegant, timeless and understated design remains as strong as ever. The curated portfolio of bespoke manufactured shower screens, enclosures and bath screens is enjoyed in discerning homes, landmark hotels and resorts throughout the world. Majestic is also recognised by leading architects and interior designers for exceptional design and performance.

The iconic Frameless, Demi Framed and Beyond Bespoke collections offer the opportunity to realise any project requirement. Standard options are available in a wide range of sizes, and 2m in height. Many Express Standard sizes can also be delivered in full within 7 days.

Majestic's real expertise though lies in a unique ability to design and manufacture bespoke solutions including panel heights of 2.4m and over incorporating complex angled cuts to help overcome the most challenging applications.

Profiles, hinges and handles are available in a wide range of finishes from the ever-popular Polished Chrome to on-trend Brushed Brass, Dark Copper and Matte Black. Glass options include Clear, Opti Clear, Bronze, Grey, Satin Edged and Mirrored. Majestic's exciting new Art Glass Collection also includes four breath-taking textured finishes in Fluted, Carved, Stone and Ice. Profiles, hinges, handles and glass can also be mixed and matched to configure individual designs for each project. A dedicated Specification Team is also on hand to take care of every detail.

In addition, Majestic has now opened a brand-new Gallery showroom at its Head Office in Dunmow, Essex. This unique design destination opens up a world of showering design possibilities and is available for architects and designers to use for meetings and to invite their own clients to visit.



Find out more at [www.majesticshowers.com](http://www.majesticshowers.com)

*Did you know  
that Long Eaton is  
renowned the world  
over as the home  
of fine upholstery*



[www.longeatonfurnituremakers.co.uk](http://www.longeatonfurnituremakers.co.uk)



LONG EATON



*Long Eaton Chamber of Trade in partnership with  
Erewash Borough Council*



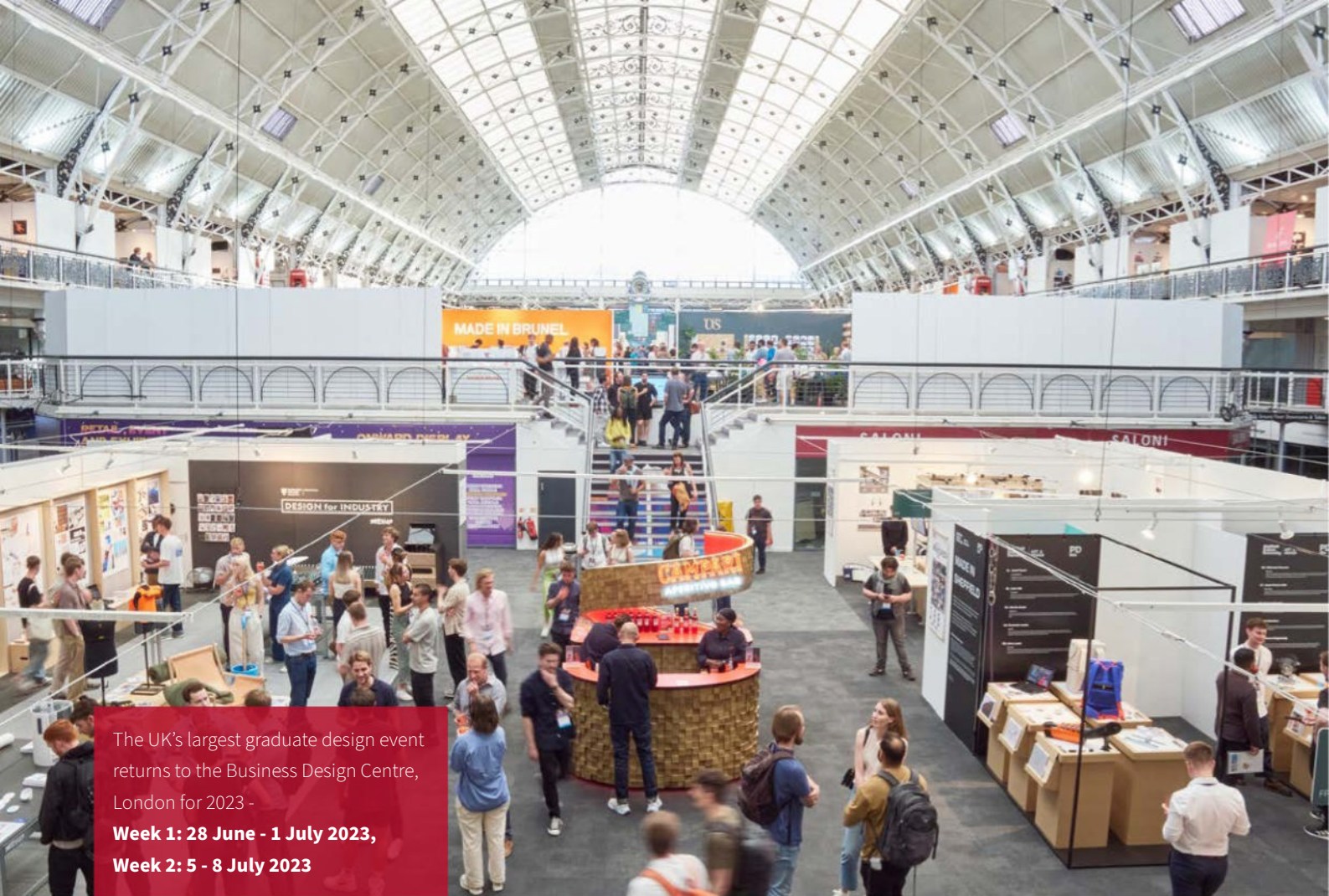

The UK's largest graduate design event returns to the Business Design Centre, London for 2023 -

**Week 1: 28 June - 1 July 2023,**

**Week 2: 5 - 8 July 2023**

# SAVE THE DATE: NEW DESIGNERS RETURNS TO LONDON FOR 2023

Immediate Media is pleased to announce that New Designers will be returning to the Business Design Centre in Islington, London from June 28th – July 1st and July 5th – July 8th 2023. New Designers will once again bring together 3,000 creative graduates under one roof across multiple design disciplines, including ceramics, fashion, furniture design, graphic design, jewellery design, product design, textiles, illustration and animation to celebrate the most innovative and exciting emerging design talent.

Founded in 1985, New Designers has helped launch the careers of some of the UK's most prolific designers including Bethan Gray, Jay Osgerby, Stella McCartney

and Lee Broom and for the last 38 years it has continued to provide a platform for graduates to present their visionary ideas to the public and industry professionals that are looking to source the most cutting-edge talent, crafts, and designs.

## ND SELECTS

ND Selects is a curated space at New Designers dedicated to shining a light on new businesses in the design industry. Visitors who attend the event ready to seek out the hottest design trends can expect to see products that have just made it to market. This area is always sought out by industry leaders who attend the show

ready to commission or invest in the latest new products and by the design conscious public looking to buy direct from up and coming designers.

Each exhibitor is hand-selected by a panel of industry experts for their innovative designs. For 2023 we are delighted to announce the curator for this year's ND Selects, Louisa Pacifico, founder of Future Icons. Louisa selects makers and designers to represent and nurture through business consultancy and curated showcases. Most notably, she developed and managed the curated showcases for The Future of Craft at London Craft Week, gallery venues within the iconic Burlington Arcade in Mayfair.

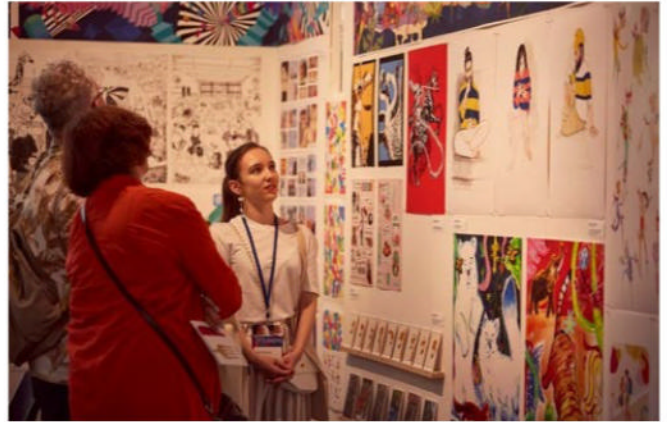

## ND AWARDS

This year's event sees the return of the New Designers Awards Programme, the prestigious awards programme which sees some of the UK's leading design brands including Hallmark, Joseph Joseph, Anglepoise, Tatty Devine and Habitat present accolades to the most creative and forward-thinking exhibitors. The 2023 show sees over 30 awards, each of which offering different prizes and industry opportunities that will help graduates' transition into the professional world.

## ND FUTURES

ND Futures is the name given to New Designers schools programme which is aimed at 15-18 year olds, offering them guidance and inspiration to consider a future career in design. For 2023 New Designers are expanding on ND Futures creating ND Futures Fund which will allow visitors to donate at checkout to support the event facilitating places for underprivileged school children in the borough to visit New Designers and start their journey on a design career.

## ND EDUCATES

The much anticipated talks and workshops programme returns for 2023 giving visitors the opportunity to hear from leading brands, designers and industry experts as they offer unique insights into the latest design trends and discuss key themes within the design sector. The full ND23 programme will be announced shortly but key emerging themes will be designing with the cost of living crisis, innovation in sustainable design and the circular economy, and diversity in design.

Confirmed highlights include; panel discussions led by editors from Creative Review and Design Week, talks by designers from Habitat, and inspiring leaders in design including Tom Faulkner, and Louisa Pacifico, Future Icons who will discuss their careers to date, as well as sessions on designing for optimism and tips to overcome creative jealousy led by artist/graphic designer June Minyama-Smithson.

New Designers - 28 June - 1 July 2023, 5 - 8 July 2023  
 Business Design Centre, 52 Upper St, London N1 0QH  
 Full ticket types and prices at: [www.newdesigners.com](http://www.newdesigners.com)

# HEATING UP YOUR STYLE: DISCOVER THE STYLISH & FUNCTIONAL WORLD OF RADOX RADIATORS & TOWEL RAILS

Radiators and towel rails are essential components of any home or commercial space and Radox radiators are designed to elevate the experience of heating with style and sophistication.

Our products are meticulously crafted to deliver both form and function, enhancing any space with their sleek designs and superior performance.

Our radiators are more than just heating appliances – they are works of art that embody elegance and luxury. Designed with the discerning tastes of architects and designers in mind, our products come in a range of stylish and unique designs that are sure to impress. From sleek, minimalist designs to more ornate and decorative styles, our towel rails and radiators are the perfect addition to any space.

With so many colour options, finishes and designs to choose from, our products can be utilised in any part of the home. A fantastic example of this is our Quartz Range of glass-fronted radiators. Whether you want a mist-free mirror in the bathroom or a radiator to match your tiles, splashback, furniture and more, these radiators can offer the perfect solution.

Each of our products is expertly crafted using the finest materials to ensure exceptional quality and durability. This combination of quality materials and expert craftsmanship ensures that our products are built to last, providing reliable and efficient heating for years to come.

Our towel rails and radiators also incorporate cutting-edge technology to deliver unparalleled performance. With options suitable for both central

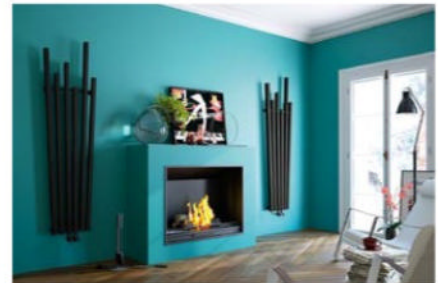

heating and electric use, we are able to provide efficient and effective heating, all while reducing energy consumption and minimizing environmental impact. We take pride in our commitment to sustainability, and as such, our towel rails and radiators are designed with the environment in mind.

Furthermore, our Quality Control team monitors every step of the manufacturing process to ensure that we offer you beautiful, durable radiators guaranteed for a minimum of 10 years, to give you the peace of mind that you deserve.

Our towel rails and radiators are the epitome of luxury, style and performance. Whether you are an architect or designer looking to enhance the elegance of a residential or commercial space, or a homeowner looking for a heating solution that combines form and functionality, our products are the perfect choice. With their exceptional quality and contemporary designs, our radiators and towel rails are the ultimate expression of elegance and style.



Phone: **01225 782 819**  
Email: **info@radoxradiators.com**  
Web: **www.radoxradiators.com**



**Manufacturers of Stylish  
Designer Radiators & Towel Rails**

01225 782 819  
info@radoxradiators.com  
www.radoxradiators.com



# TIMELESS MODERN HOUSE IN CHICAGO WITH THE KASUAL COLLECTION

KARIM RASHID'S CASUAL AND  
MODERN REPRESENTATION BY MID  
CENTURY STUDIO

Opening the door to timeless modernity and casualism in the same house is not an easy task at all, but it is an essential point these days. The needs of our daily lives have forced design to reinterpret itself, and this project is nothing more than the representation of the perfect balance of comfort, simplicity, stunning beauty, and form. This house was designed with the purpose of people spending more time inside, as home is now work, sanctuary, school, restaurant, among many other spaces.

Comprising 6 bedrooms, a living room and dining room, kitchen, and also a movie room, you have all the conditions to live an enjoyable life in this wonderful home. Located in Chicago, the third largest city in the United States, it meets all the parameters of comfort in both the cold winter and the hot summer. On the shore of the gigantic Lake Michigan, this luxurious home has beautiful views that look like a landscape from a painting. Mid Century Studio, responsible for this project, wanted to transport the beauty of nature into the house, so they included a winter garden in the center that spans the two floors with all the rooms surrounding it.

## HALLWAY

We're all familiar with "making a good impression," and this unique aisle design really delivers the perfect message to impress your guests. In this stunning look, our designers paired this exclusive piece with an exquisite lighting structure created with DelighFULL's new Kapsule suspension, designed by creative Karim Rashid.







Kapsule is a lamp that is so sculptural and so functional at the same time that it makes it timeless and precious. It is distinctive for its feminine futuristic vibe capable of making a room magazine-worthy and livable at the same time.

## KITCHEN

Next up is a fabulous luxury kitchen design with high-end custom cabinetry made with



a combination of dark marble and wood. This unique kitchen set was complemented with other sophisticated black and gold elements, such as the unreleased Mid-Century Club bar chairs on the kitchen island, exclusively chosen and shown for the first time in this project, or Karim Rashid's Katia pendant lamps above it.

DelightFULL's Katia lighting collection is like a constellation of endless possibilities,

whether singular or grouped together.

This mushroom style pendant lamp has a curved brass shade and a cylindrical body, evoking a 70's feel. A pendant lamp that was first available in 2021, yet it could easily be mistaken for a European flea market find. This mid-century modern lamp is more oblong than another mushroom-style lamp, due to its unique silhouette that we probably won't find often.

## DINING ROOM

Since the open concept is the key element of this unique project, guests have the opportunity to see the dining room as they are comfortably seated in the living area. This large dining space features a luxurious look complete with Karim Rashid's incredible Krown lamp that brings exquisite light and style to this unique space with its grandeur and sophisticated lines, complemented by the beautiful Bertoia marble dining table and Isadora dining chairs from Essential Home.

This lamp by DelightFULL is synonymous with sensuality, with its old-fashioned facets and the stereotypes of lighting history, while still maintaining its beauty. Its geometry of shades combined with its handmade brass frame is the true statement of luxury.





## CINEMA

For any cinema room, comfort and lighting are very important. The comfort is guaranteed with the sofa from Essential Home and the lighting is perfect with the beautiful Miles table lamp from DelightFULL. A classic mid-century modern table lamp that brings back the sophisticated atmosphere of the 1950s. A very sophisticated fixture that sits well in any room, we can see it in this cinema, as in a bedroom or even in an office.

FOLLOW US:  
[@delightfull](https://www.instagram.com/delightfull)

Images ©DelightFULL



# Revivalist<sup>R</sup>

BRINGING DESIGN & INTERIORS TO LIFE

## Contract Furniture Specialist

Furniture for the leisure and hospitality industries,  
handcrafted delivered and installed by Revivalist



TAILORED SOLUTIONS FOR YOUR BUSINESS

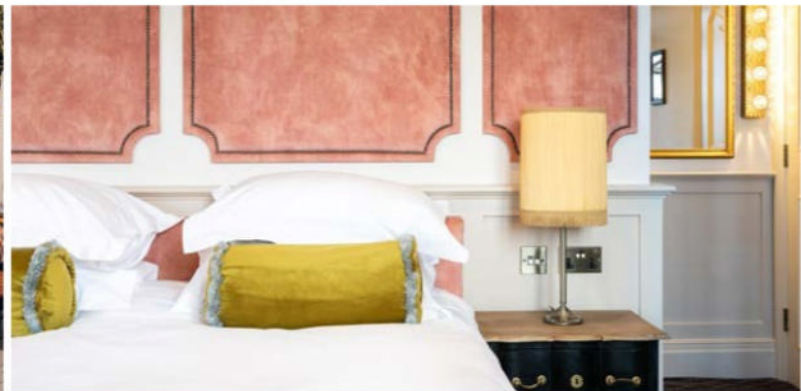

[www.revivalist.co.uk](http://www.revivalist.co.uk)

01302 639210 | Email: [info@revivalist.co.uk](mailto:info@revivalist.co.uk)

# BASALTE

## DESIGN FOR YOUR INTELLIGENT HOME



Basalte was founded with a mission to unite high-quality design and intuitive smart home technology. A unique combination that remains a fundamental part of our DNA. We want to keep things simple and elegant, both in form and function.

Our multifunctional design keypads, refined speakers and elegant iPad mounts can be found in the most luxurious projects all over the world. Pushing towards the limits of perfection, we strive to reshape the way people live by making everyday actions easier and bringing true comfort to your home.



### YOUR HOME, AT THE SLIGHTEST TOUCH

Imagine. At the slightest touch the room dims to the right scene, music starts playing, the temperature rises and the curtains close. Ready for a cosy evening. The integration of all these functions in an intelligent and user-friendly system is Basalte Home, the future of the modern home. Personalise your home down to the finest details and control it all with a gentle touch of your app, keypads and design remote.

### ADELANTE, WELCOME HOME

**Adelante is our new luxury door phone for Basalte Home.** See who's at your doorstep, talk to them and let them in using our Lisa, Ellie and Lena displays and our Basalte app. Sophisticated, sleek and only available in high-quality finishes, your door phone is no longer a necessity. It's a design statement perfectly integrated into your Basalte Home. Completely customisable to reflect your aesthetics and to match our full product line.

### PASSION, DEDICATION AND TRUE CRAFTSMANSHIP

We believe that the most exclusive materials and fabrics should be treated by craftspeople with a passion for their work. All products are meticulously designed and handmade with love in Belgium.

[www.basalte.be](http://www.basalte.be)

welcome home,  
adelante



Welcome home, **Adelante**. The luxury door phone for your Basalte Home. The first look. The first moment at your doorstep. You know you have arrived at a remarkable place.

**basalte**  
design for your intelligent home

# JOANNA BIRD CONTEMPORARY COLLECTIONS

## rites of passage

19 Grove Park Terrace, London W4 3QE

JUNE 8<sup>th</sup> – JULY 19<sup>th</sup> 2023

Joanna Bird is excited to be presenting a selection of original new work for our forthcoming June Exhibition, Rites of Passage.

The artists for this ground-breaking exhibition include: Emmanuel Boos, Carina Ciscato, Hanne Heuch, Akiko Hirai, William Plumptre, Matthew Warner and Gregory Warren Wilson. Also, Past Masters: Richard Batterham, Bernard Leach and Lucie Rie.

This exhibition focuses on the important aspect of influences on artists in developing their own styles. For example, the influence of Tatsuzo Shimaoka on William Plumptre's work and that of Jean Girel on the glazes produced by Emmanuel Boos are both clear to see.

The curation juxtaposes contemporary and historic pieces thereby demonstrating the lineage of influences.

The Private View for Rites of Passage will be held on June 7th, at the above address, and the exhibition continues until July 19th 2023.

Joanna Bird originally trained as a potter with Michael Cardew before setting up a contemporary ceramics gallery in 1994. Over the last three decades she has built an international reputation as a leading ceramics and glass expert and is regularly consulted by Museum curators and private collectors on important acquisitions.

An illustrated catalogue for the exhibition will be available.

**Evening events accompanying the Exhibition to be held in association with the Joanna Bird Foundation can be found on our website.**



**Time Rock Stack III**  
by Dawn Bendick  
Cast dichroic glass, H 31 x W 14 x D 12cm

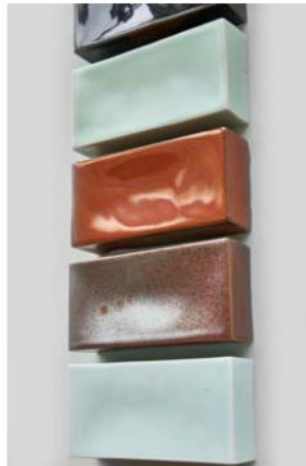

**Ladder Installation**  
by Emmanuel Boos porcelain,  
iron based glazes 150cm x

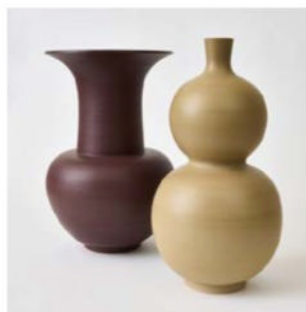

**Two Vases**  
by Matthew Warner stoneware  
with burnish porcelain slip left to  
right H 41 x D 25cm H 42 x D 23cm

*Prometheus Descends With Fire For Mankind*

by Gregory Warren Wilson

Hand cut glass with gold glass

H 122 x W 45 x D 5cm, 2023



Address: 19 Grove Park  
Terrace, London, W4 3QE

Tel: 0208 995 9960  
Email: [info@joannabird.com](mailto:info@joannabird.com)  
Website: [joannabird.com](http://joannabird.com)

# FEATHR LAUNCHES ECO PRO WALLCOVERING, **THE SUSTAINABLE SOLUTION FOR HOMES AND HOSPITALITY PROJECTS**

Feathr, The Home of Artisan Wallpaper, is proud to announce the launch of its new Eco Pro wallcovering material, the eco-friendly replacement for vinyl wallcoverings.

This weighty, textured wallcovering is PVC-free, FSC™ certified, and REACH compliant, making it the perfect choice for restaurants, hotels, offices, and any project where sustainability is at the heart.

Eco Pro is made with environmentally friendly inks (UL ECOLOGO®, UL GREENGUARD GOLD Certified) and features a textured/canvas feel with a weight of 230gsm. The wallcovering can be installed easily by applying paste directly to the wall, making it DIY-friendly. The washable surface ensures that the wallcovering is easy to maintain, while its fire rating (Europe B-s1. d0, USA Class A, ASTM E84) makes it a safe choice for any project.

“We believe that greener choices contribute to our happiness, our well-being, and our health,” said Tom Puukko, Founder of Feathr. “That’s why we are excited to introduce Eco Pro, a wallcovering that performs like a contract grade vinyl but does not contain potentially harmful components. With its sustainable features and durability, Eco Pro is the perfect choice for those who are passionate about both style, performance and sustainability.”







In addition to being available for all Feathr wallpapers, Eco Pro is also available for bespoke designs developed especially for project needs. Feathr's large artist network combined with a skilled inhouse design team makes the company the perfect partner for projects that require a bespoke design vision.

The wallcovering is CE Compliant according to EN 15102:2007 + A1:2011 and is non-phthalate. Panel widths of 50cm (19.7") and 100cm (39.4") are available, and the wallcovering is perfect for both home and hospitality projects.

Eco Pro is available for order now for worldwide delivery with a minimum order of just 3sqm / 33 sq ft. Prices start from \$60 / €52 / £43 per square meter or \$5.60 / €4.85 / £4 per square foot (excluding local sales taxes). Feathr is excited to bring this sustainable solution to customers who are looking to create beautiful residential and commercial spaces while making environmentally conscious choices.

[www.feathr.com](http://www.feathr.com)

# CARPET RECYCLING UK: STRENGTHENED WITH 80% SUPPORT FROM CARPET AND TEXTILE FLOORING SECTOR

Following significant growth in its membership network, Carpet Recycling UK (CRUK) is seeking more engagement from the construction, facilities management and flooring sectors to act to reduce textile flooring waste such as commercial broadloom carpet, carpet tiles and underlay.

The not-for-profit association reports that working with 80% of the UK's carpet and textile flooring manufacturers and distributors puts it in a stronger position to represent the sector when it comes to discussions on favourable Government policy outcomes.

Support from CRUK's 17 core members comes from Balsan, Betap, Brintons Carpets, Condor Group, Cormar Carpets, ege Carpets, Furlong Flooring, Gradus, Headlam Group, IVC Commercial, Likewise Floors, Milliken, Modulys, Rawson Carpet Solutions, Shaw, Tarkett and Victoria Group. They are taking voluntary producer responsibility for the products they place on the market and striving to reduce waste in production as well as for their customers, helping to create cost savings.

Commenting on their focus for 2023, Adnan Zeb-Khan, CRUK Scheme Manager says: "In our 15th year, the 80% industry support adds weight to our representation for the sector, recognising the achievements of our members and wider network, as we continue to help the sector to develop sustainably.

"Moving forward, companies will need to demonstrate reductions in use of new resources, design products with recycling in mind, include methods of identification of

material make up and consideration of reverse logistics for take-back and recycling outcomes. Our members are making great strides ahead with many developing products with recycling in mind, from single polymer ranges, to ranges made with recycled content."

For the construction sector, developers and facilities companies interested in sustainable solutions to flooring waste, CRUK offers an extensive network of specialists handling surplus and used textile flooring waste, such as carpet tiles, carpet rolls and clean installation offcuts. Adnan continues: "New homes flooring contractors, for example, are already segregating carpet and textile flooring waste for reuse and recycling. They recognise the savings in resources and costs associated that they have achieved and the benefit of their connection with us when tendering for new work."

David Heafey is Finance Director of CRUK member Saint Flooring, who implemented waste material recycling throughout the company's nationwide sites in 2019. He says that membership of Carpet Recycling UK is contributing to their sustainability goals and helping to achieve annual savings of up to £170,000 a year on disposal costs by reusing and recycling their waste materials, including carpets. "Carpet Recycling UK supported us throughout and our membership helped us to find partners to recycle the carpet. Without being a member, I do not think we would have had this success."

CRUK's 136-strong membership includes specialist reuse and recycling members repurposing surplus flooring for reuse and

recycling in feasible outlets or used as an alternative fuel source. Adnan observes: "Our ultimate aim is to move carpet and textile flooring up the waste hierarchy and create circularity to maximise the use of these resources. Obviously, preventing this material becoming a waste by reusing flooring in new settings is the best outcome for unwanted and surplus material. This helps to provide affordable flooring for social housing tenants and low-cost flooring for property developers. That's why we're inviting companies to discuss their projects with us."

Key to CRUK's work is collecting accurate data on the volume of carpet and textile flooring placed on the market together with tonnages for waste material which is being diverted from landfill – it is estimated that of the 470,000 tonnes arising in 2020, 70% was diverted from landfill. The latest figures due back from the 2021 tonnage survey will be presented at CRUK's annual conference on June 21-22 for which early registration is advised. "Given the heightened interest in legislation issues, developments and challenges surrounding the treatment of textile flooring related wastes, we're expecting high demand for our conference," adds Adnan. "In just 15 years, we have come a long way in developing solutions for carpet and textile waste that preserve valuable resources and reduce costs for the supply chain.

"We want to reach more companies who would like to find sustainable solutions for their waste carpet and textile flooring material that help to reduce the impact this waste stream has on the environment. Thanks to our rapidly growing network, we can help you."

For our Directory and more information, email: [info@carpetrecyclinguk.com](mailto:info@carpetrecyclinguk.com) or visit [www.carpetrecyclinguk.com](http://www.carpetrecyclinguk.com).

## Join Carpet Recycling UK to help make the UK carpet sector more sustainable!

With the help of Carpet Recycling UK, our members and wider network diverted 330,000 tonnes of waste carpet and textile flooring from landfill in 2020, approximately 70% of the total textile flooring waste arising in the UK. How can you help to increase this?

- C** Carpet Recycling UK is a not-for-profit membership association set up in 2007.
- A** We are an **association** of 136 member companies.
- R** We **respond** and advise on best practice for reuse and recycling of commercial textile flooring waste.
- P** We **provide** support and advice throughout the supply chain to include flooring manufacturers, contractors, retailers etc.
- E** Members are **encouraged** to demonstrate their progress by sharing stories/case studies as well as entering our awards.
- T** **Textile flooring** includes broadloom carpet, carpet tiles, planks, event carpet, rugs and underlay.
- W** We engage with the supply chain to identify and promote Circular Economy initiatives.
- A** We **assess** your waste to find the most feasible, cost-effective recycling options.
- S** We demonstrate and promote **sustainability** through design for recycling initiatives.
- T** Surplus, offcut and used **textile flooring** can be reused or recycled, contact us!
- E** Talk to us at our **events** – join our network!

### Contact Carpet Recycling UK

Carpet Recycling UK is a not for profit organisation funded by companies across the supply chain to develop more sustainable and environmentally friendly solutions for carpet waste. Our ability to network with our members and wider network helps to provide you with the most feasible solutions to send your waste up the waste hierarchy and prevent waste being sent to landfill. Please visit our website for more information.

[www.carpetrecyclinguk.com](http://www.carpetrecyclinguk.com)

Thank you to our Core Members

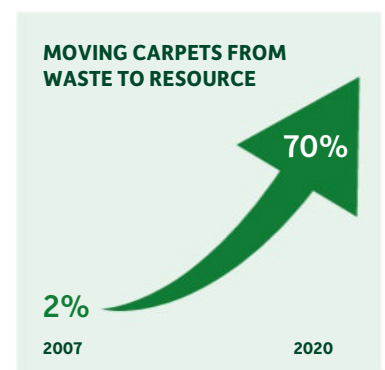



After the homeowners acquired this beautiful three storey Edwardian property, they dreamt of transforming it into an inviting home which felt as welcoming as it did luxurious.

# A SHOWCASE OF STUNNING SYMMETRY IN EDWARDIAN PROPERTY

Taking inspiration from the opulence of hotel rooms each room was meticulously planned and designed down to the most intricate detail. Having enlisted the help of Krantz Designs, the result is a stunning home with a harmonious collection of practical spaces.

The heart of any home is of course the kitchen and this one certainly does not disappoint. Symmetry was at the forefront of the design concept and this really reads well in the kitchen of this home, offering framed views through the orangery at every angle. The purpose to extend and create the orangery in this three storey Edwardian home, was to create a multifunctional open plan kitchen, dining and snug which acted as a core for the home – The design achieves that in so many ways.



This really is a chef's kitchen, with full height storage and refrigeration positioned directly behind the impressive La Cornue

cooker on the central island. There are hidden surprises in every cabinet or drawer you open, leaving no stone unturned. The breakfast pantry sits adjacent to the low integrated breakfast table offering a practical flow for the user. The coffee machine inside accompanied by the mini prep sink and hot tap, hidden chopping block and cutlery storage create a self contained drinks making station. This not only ensures that the chef in the space is able to cook with no interruptions, it makes for an impressive entertaining area suitable for family life.

In addition to the kitchen space the utility of the property also underwent a transformation. The property is home to two dogs and the homeowners have a son who loves to play sport. A space to throw off



muddy boots and ample storage for hanging coats and shoes was imperative. A full height housekeeper's cupboard hides away the essentials such as the vacuum, cleaning products and mop.

As well as a practical space this room also needed to accommodate the owner's hobby of flower arranging. Full height storage cupboard housing flower arranging supplies such as ribbon and vases, mirrors the housekeepers cupboard. Directly opposite a Belfast sink station with expansive worktops and an undercounter bin creates a practical and useful flower arranging zone.

A cinema room provides a versatile space for the homeowners. Exuding comfort this room is a contrast to the light and airy feel throughout the rest of the property. The dark hues with the addition of the antique brass metal detailing create a vibe that really exaggerates opulence and luxury.

Krantz Designs appointed cinema experts Pure Theatre to determine the best products to create a truly immersive experience whilst also achieving beautiful aesthetics. As specialists in concealed home cinemas, Pure Theatre were able to specify a projector screen and projector lift which recessed all of the equipment in the ceiling. The room features both a television

and motorised 104" projector screen for those all important movie nights. Even the projector hides away in a projector lift, which has been painted to blend beautifully with the ceiling. As well as looking great this room sounds amazing thanks to a 5.1.2 surround sound system featuring three in-wall speakers and four in-ceiling speakers.

Moving upstairs, the master suite has also been re-imagined. The main design principle for this room was to create an impact on entry with a statement headboard. Delicate and intricate detailing offers a touch of opulence and luxury. Symmetrical access left and right of the bed entices you through the 'His' and 'Hers' dressing room spaces before arriving at the main bathroom.

The design is the perfect balance of serenity and luxury and clever use of layering materials and finishes really add to the ambience as you lead through the floorplan. There is a constant desire to see more, and the element of surprise as you unveil more of the hidden spaces behind the headboard are really what give you an immediate sense of 'wow'.

Guests to the property have not been left out, with a newly fitted guest bedroom. What was a very tight, compromising space has been

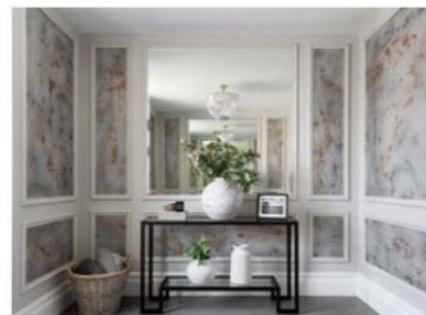

transformed into a tranquil bedroom. The use of mirror on the bespoke headboard detail made what felt originally a very tight space, feel a spacious inviting room to enjoy. The mirrored details are repeated all the way through the room, where it can be seen incorporated on the floating dressing table drawer. The freestanding bed became part of the headboard and the floating drawers instead of solid bedside tables gave the illusion of the space being much bigger.

Every part of this Lincolnshire home invites you to stay just a little longer. We are sure the homeowners will spend many happy years enjoying their newly revitalised property.

[www.puretheatre.com](http://www.puretheatre.com)  
[Krantzdesigns.co.uk](http://Krantzdesigns.co.uk)

Images credit: Photography by Paul Craig

# DOOR CLOSER DEVICES IN LUXURY DESIGN



With new responsibilities on Principal Designers, there's a growing demand for compliance.

Rutland are probably best known for their primary fire testing, but also for their concealed closer and designer finishes.

This has been welcomed by designers keen to protect their clients, without limiting creativity.

*"When fire safety is truly integrated within a building's design, lives are saved, and property is protected",* according to Neil Smith at Rutland Door Controls. *"That's our focus - enhancing safety with effective door controls"*

The difficulty of finding certified, fully-compliant doorsets at the bespoke, designer end of the market is a challenge that many designers will recognise.

## Principal designer of high-risk buildings (HRB)

Following the latest updates to the Fire and Building Safety Acts, there is a clear responsibility on designers to specify fire-rated doors, with self-closing devices on apartment entrances that open into the communal area.



## SWD Bespoke door designs choose the Rutland Concealed Closer

SWD Bespoke door manufacturers rose to the challenge and developed a fire-door tested to 2.7m high and 1m wide; near the maximum size for a furnace – SWD Bespoke claim this gives them ample scope for oversized doors; so sought after in the luxury homes market. According to SWD's offering, they can manufacture fire-rated doors up to a huge 2.9m in height.

The doorset has achieved PAS24 security, designers can choose handles styles, through to metal door inlays, leather or veneer facing and more. According to SWD Bespoke, all these options are tested for fire and security compliance with PAS24 and FD30 requirements.



Crucially for apartment entrance doors, the door is supplied with the Rutland ITS 11204 concealed door closer. In addition to safety, this door closer device provides internal doors with a precisely controllable, auto-closing and anti-slamming function, giving a much better feel of quality.

Rutland's ITS 11204 was chosen by SWD as its discreet, concealed design means only the connector bar and slider arm are ever visible. In line with the highly customisable concept of the door, the Rutland ITS 11204 is available in polished brass, antique brass, silver, satin nickel, and polished nickel. The adjustment options allow for controlled opening, closing, latching and stay-open on a wide range of door sizes and weights.

Aside from the fire and security aspects of Rutland door controls, the closer devices lend themselves to clients who appreciate the additional functionality and safety. Many of Rutland's door closers can be supplied as hold-open devices (for non-fire doors), preventing doors from striking walls and expensive furniture, whilst reducing the risk of finger entrapment if heavy doors slam shut.

## Door Control Training for Designers

RIBA have recently approved Rutland's CPD 'Design considerations for fire door control and understanding today's fire door challenges' specifiers and principal contractors can book RIBA-approved Door Closer Device course from Rutland ([www.rutlanduk.co.uk/cpd-training](http://www.rutlanduk.co.uk/cpd-training))

## Author: Ben Smith, Fabrico

*Ben is a writer for the built environment niche, covering architecture, building safety standards, sustainability and development*

[rutlanduk.co.uk](http://rutlanduk.co.uk)

Image credits: SWD Bespoke (<https://swdbespoke.com/>)  
Maverick London (<https://mavericklondon.co.uk/>)  
Rutland (<https://www.rutlanduk.co.uk/>)



It's a fine line between safety and tragedy.

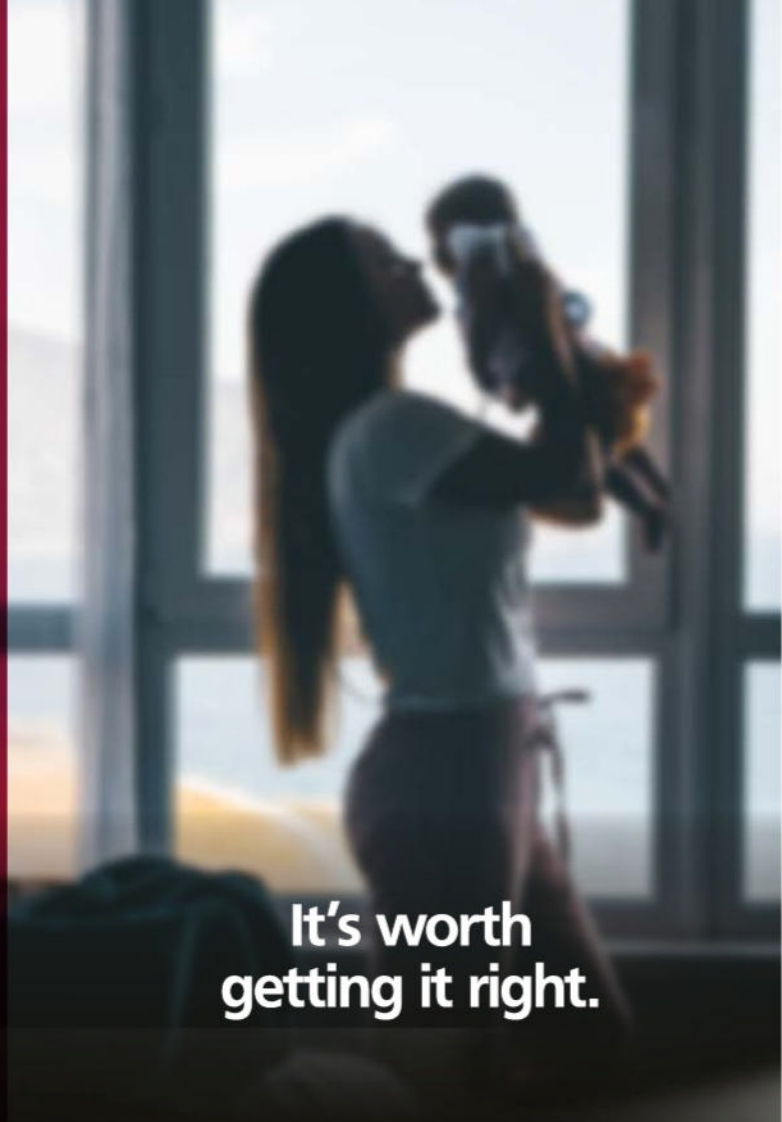

It's worth getting it right.

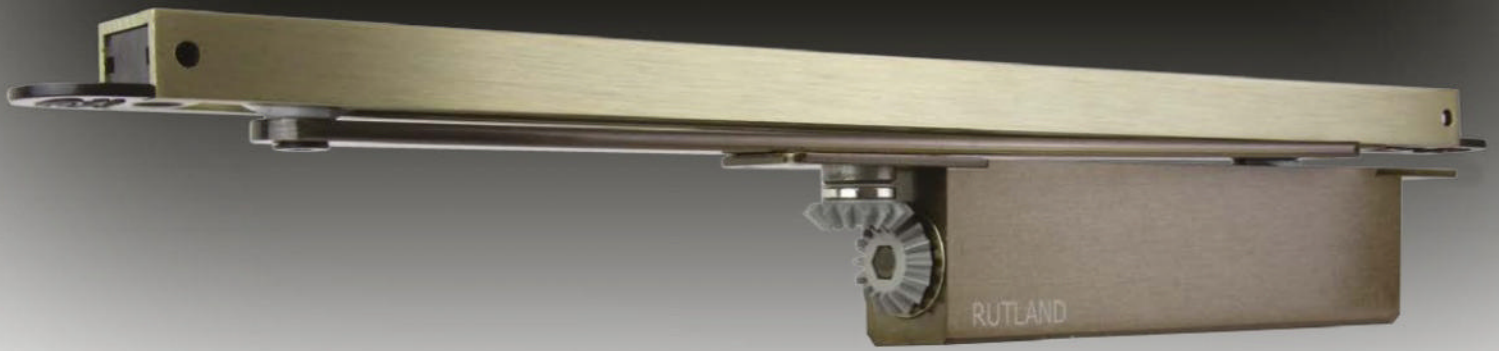

[rutlanduk.co.uk](http://rutlanduk.co.uk)

Scan code for RIBA Approved CPD training



Style with Safety. With concealed door closers you don't have to compromise.



# CELEBRATING THE ANIMAL KINGDOM



For Spring Summer 2023, Laliqque is celebrating the animal kingdom – a theme dear to Rene Laliqque.

The new 'Empreinte Animale' collection pays tribute to wildlife in all its splendour. It invites us to dive into a dreamlike jungle where feathers, fur and scale are tamed in crystal. With a realism that is true to life, the know-how of the masters of fire, Laliqque artisans at the Alsace workshops, offer a perfect replica of the animal materials – scales, feathers and skins. Impressive and sculptural with meticulous attention to

detail – each piece in the collection saluting the art of crystal haute couture, unique to Laliqque.

The contrasting Zebra motif celebrates the natural geometry of this iconic symbol of the Savanna. The clear satin-finished and re-polished versions offer plenty of scope for interpretation. The captivating black and white stripes on the crystal create a hypnotic visual effect. Highly realistic, they run through the anatomy of the vase, the shape of which is inspired by the curves of the animal, combined with detailed enamelling work which is highly technical.

Impressive and sculptural, the Crocodile motif captures all the graphic power of this fearsome animal. The meticulous detail of the scales and the crystal relief are a real technical achievement, giving it a striking realism. Bold and intriguing, the crystal skin is an irresistible invitation to touch.



LALIQUE

[laliqque.com](http://laliqque.com)



# LALIQUE



## SERENE AND SPACIOUS LIVING THE ASH TREE FARM PROJECT BY HAWWOODS

Located in the scenic town county of Yorkshire, surrounded by rolling hills, this former farmhouse has been transformed into a spacious and modern family home with flooring from Hawwoods, combining contemporary amenities with plenty of original personality – from the large windows to the charismatic stone feature wall.

The homeowners chose two dynamic flooring solutions from Hawwoods' Italian Collection for their hallway, living space and kitchen – Columba Select 70mm Block and 120mm 1-Strip. Offering durability and style, the Italian Collection is best known for its narrower planks in an array of colours and styles, providing complete flexibility in the home with engineered boards made from FSC® (FSC-CO09500) Certified Timber that are suitable for underfloor heating.

The Block planks create a seamless flow from room to room, achieving a cohesive aesthetic that complements the homeowners' pared-back décor. Complemented by plenty of natural light, the warm undertones of the honey-coloured



flooring help to reflect light around the room and add to the feeling of space. The flooring in the hallway is paired with a darker colour palette in the form of teal, velvet armchairs, a dark sofa and black detailing including the front door and window frames, which is then carried through into the beautifully designed kitchen.

Providing the perfect backdrop to the home's traditional features including detailed panelling and coving, the Block planks create a warm and inviting atmosphere that complement

the shaker-style kitchen. The two-tone palette, comprised of off-white and dark blue cabinetry, highlights the natural varying colourways of the flooring, helping to add depth and texture to the space.

Adding intricacy to the home, Hawwoods Columba Select 120mm 1-Strip boards have been used as stair treads with narrow black borders, creating natural zoning within the home, while remaining cohesive within the rest of the scheme.

[www.havwoods.com/uk](http://www.havwoods.com/uk) | [info@havwoods.com](mailto:info@havwoods.com) | +44(0)1524 737000

## CONCRETE OIL

For concrete, stone & tiles



- Natural Ingredients
- Highly Water Repellent
- Protects Against Dirt & Wear
- Enhances the Natural Surface

[www.osmouk.com](http://www.osmouk.com)



# FRENCH LUXURY CROWNS THE PERFECTED DESIGN EXPERIENCE

Complete, perfected, perfection. Carpe Diem Beds, the lifestyle brand that creates unique and well-designed bedroom environments you never want to leave, raise fashion to become a central piece of its concept.



This spring a Limited Edition for 2023 will be launched featuring the classic houndstooth pattern, known from Christian Dior and often associated with Jackie Kennedy. A dazzling version breathing of French luxury mixed with the feeling of Carpe Diem Beds heritage from the Swedish west coast and its nature from which it all stems. A perfect blend of chic aesthetics and top-modern Swedish craftsmanship. The attached press release describes this year's Limited Design Edition in the exclusive fabric, including the sweetest dog bed, but also new products in the Rörö, Rivö and Vallerö series, all handcrafted in Sweden, as well as the silky-smooth bed linen Vindstilla.

Carpe Diem Beds has been developing beds for over 25 years with the goal of creating a feeling of near weightlessness and amazing comfort. The founder, Börje Thuleskär, used his knowledge from his chiropractor profession and through a collaboration with

the Spinal Unit at Sahlgrenska University Hospital in Gothenburg to lay the foundation for the first models and Carpe Diem Beds' patented Contour Pocket System. Carpe Diem Beds is much more than a bed, it is a lifestyle brand that put focus on the entire design experience. The beds are designed to be as beautiful to look at as they are comfortable. A complete design experience for the bedroom that allows you to create an individual retreat in which you can relax completely and never want to leave.

## LIMITED DESIGN EDITION 2023

Let the French world of fashion unite with the beautiful and natural Swedish aura that Carpe Diem Beds represents. The Design Edition 2023 is a limited edition inspired by Carpe Diem Beds' Swedish heritage and the

graphic tones characterising the nature around the country's west coast, and the exclusive feeling reinforced by the classic houndstooth patterned textile with strong roots in French fashion houses like Christian Dior. An elegant and timeless classic that never goes out of style – the perfect match with Carpe Diem Beds' soul and range.

*With this Design Edition 2023 in the classic houndstooth pattern, we combine qualities from the world of fashion with high recognition that exudes the same timeless and at the same time eternally modern design, with our vision of a bedroom so appealing, timeless, and elegant that you never want to leave it, says Nanna Backman Head of Product Development at Carpe Diem Beds.*

The Limited Design Edition 2023 in houndstooth pattern is applied to Carpe Diem Beds' most popular continental bed, Sandö, which, like the rest of Carpe Diem Beds' range, is made in Sweden.

### **SURROUND YOURSELF AND YOUR LOVED ONES WITH THE NEW LIMITED EDITION 2023**

Decorate with fashion and create a bedroom environment you never wish to leave. In addition to the limited edition of the Sandö continental bed, the classic French pattern will be applied to a dog bed, throw pillows, and footstool/pouffe, too. Everything designed to offer you the complete bedroom experience.

[Carpediembeds.co.uk](https://carpediembeds.co.uk)  
[@carpediembedsofsweden](https://www.instagram.com/carpediembedsofsweden)





- Lightweight very compact lift.
- Designed specifically for small TVs Maximum capacity 10kg.
- Adjustable 600mm stroke. 500mm height.
- Optional lid lifter and VESA bracket set.
- TS600B can be used upside up or upside down or laid flat to open a drawer on runners. RF control.

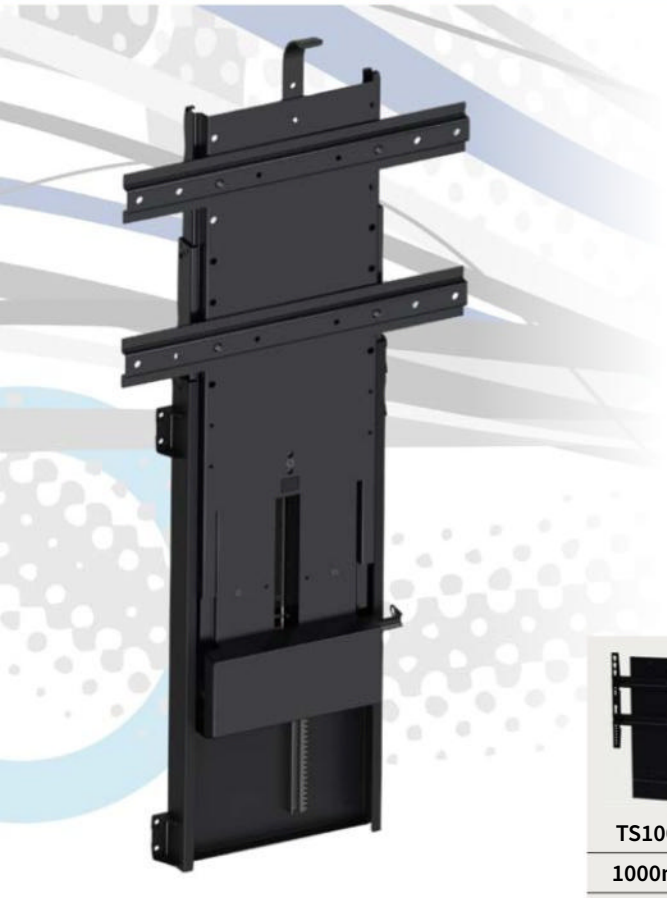

TV Lifts since 2005



<b>RF control</b> <b>Adjustable Stroke</b> <b>Safety stop</b>			
	<b>Model</b>	<b>TS700C&amp;A</b>	<b>TS1000C&amp;A</b>
	<b>Stroke/capacity</b>	<b>700mm/65kg</b>	<b>1000mm/65kg</b>
<b>Min install height</b>	<b>650mm</b>	<b>750mm</b>	

<b>TS1000C twin</b>
<b>1000mm/65kg</b>
<b>750mm</b>



TS700 and TS1000 have a high lifting capacity of 65kg upright or 29kg if used upside down. Both A and C versions have a setting option for collision safety on the downward stroke and type C also has this on the upward stroke.

Type C has an additional electronic stroke adjustment. Type A has just a mechanical adjustment.

Two TS1000C lifts combine as one to create a heavy duty extra stable screen lift, ie for flight cases or for a wide wall mounted screen.

UK +44 (0)1245 477922 • [venset@interlineuk.com](mailto:venset@interlineuk.com) • [venset.com](http://venset.com)

UK trade distributors: Furniture manufacturing: [Hafele.co.uk](http://Hafele.co.uk) | 0800 171 2909

AV manufacturing: [Screenlifts.co.uk](http://Screenlifts.co.uk) (Loxit) | 01625 365184



501-11 Heavy duty

↑ 122 cm ↓ 65 cm      150 kg ↑↑↑

**ConSet**

Electric tables and frames since 2000

## A world of choices & huge stocks

- ConSet design and manufacture all their own electric mechanisms and frames
- Heavy duty, standard duty, shallow tops, deep tops, 120 degree, L shape, back2back, very large, very small and even mobile via a battery pack.
- Black, silver, white and chrome options
- Testing: a multitude of testing exists throughout the product range
- ConSet electric frames with or without table tops are sold throughout the UK and Ireland via ConSet retail dealers and furniture manufacturers
- **Denmark to the UK every week - the average electric frame stock status through 2022 exceeded 90%**
- **ConSet Desks Ltd** UK trade supply for onward retail via a network of UK and Ireland approved stockists and manufacturers
- ConSet A/S is a Danish company run and owned by its founders.
- The products are sold worldwide.
- ConSet desk frames have been sold in the UK since 2003.



↑ 122cm ↓ 57cm      100 kg ↑↑↑

501-37 Versatile



501-25 Very tough

↑ 120 cm ↓ 68 cm      120 kg ↑↑↑

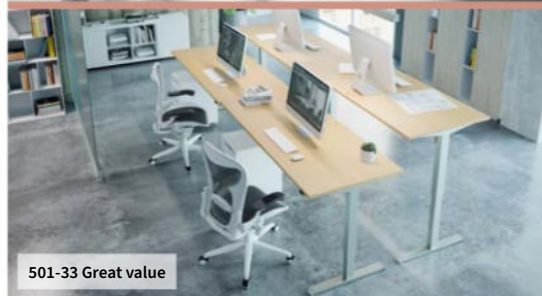

501-33 Great value

These photos show a very small selection of the vast range. VenSet and ConSet are founded by the same owners, both brands have an extensive global presence of dealers, distributors and sales offices. Known all over the world with a well established and proven product history.

UK +44 (0)1245 477922 • [conset@interlineuk.com](mailto:conset@interlineuk.com) • [conset.org.uk](http://conset.org.uk)

All published prices are suggested retail ex VAT

## Beautiful Designer Ceiling Fans



Stylish - Reliable - Silent



**THE HENLEY FAN COMPANY LTD**

**01256 636 509**

**www.henleyfan.com**



## MAKING INTERIORS SMELL AS GOOD AS THEY LOOK

Have you ever entered a space and instantly felt at home, or quite the opposite, uncomfortable or anxious?

The reason why is not always an evidence, be it the colours, the lighting, the furniture or perish the thought... the SMELL! A badly aligned interior may have you longing for more or running for the door.

Aromatise Fragrance Diffusion Technology believe in the art of aligning those senses, with the help of the often-forgotten sense of smell. With premium perfumes and state of the art fragrance diffusion



technology, we will assist you in designing the olfactive completion of any living space.

Do call us and speak to us personally for an easy first consultation or visit us on our website.

**AROMATISE**

Web: [www.aromatise.co.uk](http://www.aromatise.co.uk)  
Email: [info@aromatise.co.uk](mailto:info@aromatise.co.uk) | Tel: **01223 894207**



## Design & Display Structures RETAIL FIT OUT COLUMNS



- Elegant cloaking of your support structures
- Robust construction resisting people loads
  - Quick to install • Fire rated
- Available in a wide range of sizes, configurations and RAL/BS colours
- No follow on wet trades required as fully finished in the factory offering easy clean low maintenance surface

For more details contact Design & Display Structures  
Allan Curtis 07718 320184 • [design-and-display.co.uk](http://design-and-display.co.uk)

**COMPLETE  
FITTED FURNITURE**  
*Richard Phillips*



## GET INSPIRED

BECAUSE ALL HOMES ARE BUILT ON LOVE

DISCOVER THE COMPLETE COLLECTION  
[COMPLETEFITTEDFURNITURE.COM](http://COMPLETEFITTEDFURNITURE.COM)

BERKHAMSTEAD | WATFORD | AMERSHAM  
01442 777 111 | 01923 224 000 | 01494 434 363



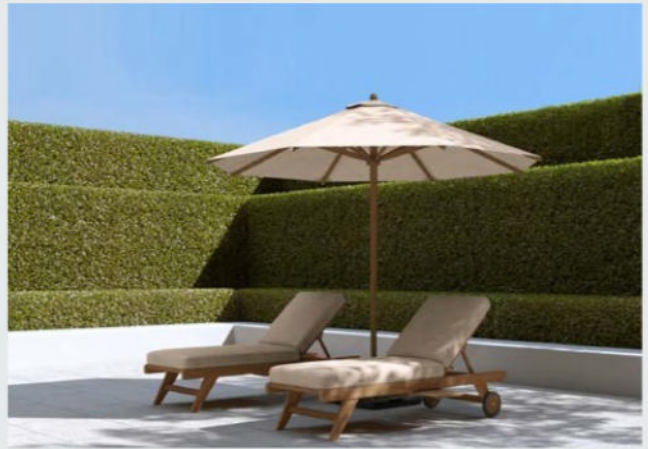

# CHIC TEAK

TIMELESS TEAK FURNITURE.  
TREASURED FOR GENERATIONS.

All of our teak comes from ecologically managed and sustainable plantations and has been certified by the Indonesian Government. We only design and sell the very best teak outdoor furniture, using the finest A grade teak with everything finished by hand from our suppliers using skilled craftsmen. All our garden furniture is delivered fully assembled by our in house team.

# BATHROOM DESIGN STANDS OUT FROM THE CROWD **WITH KOY**

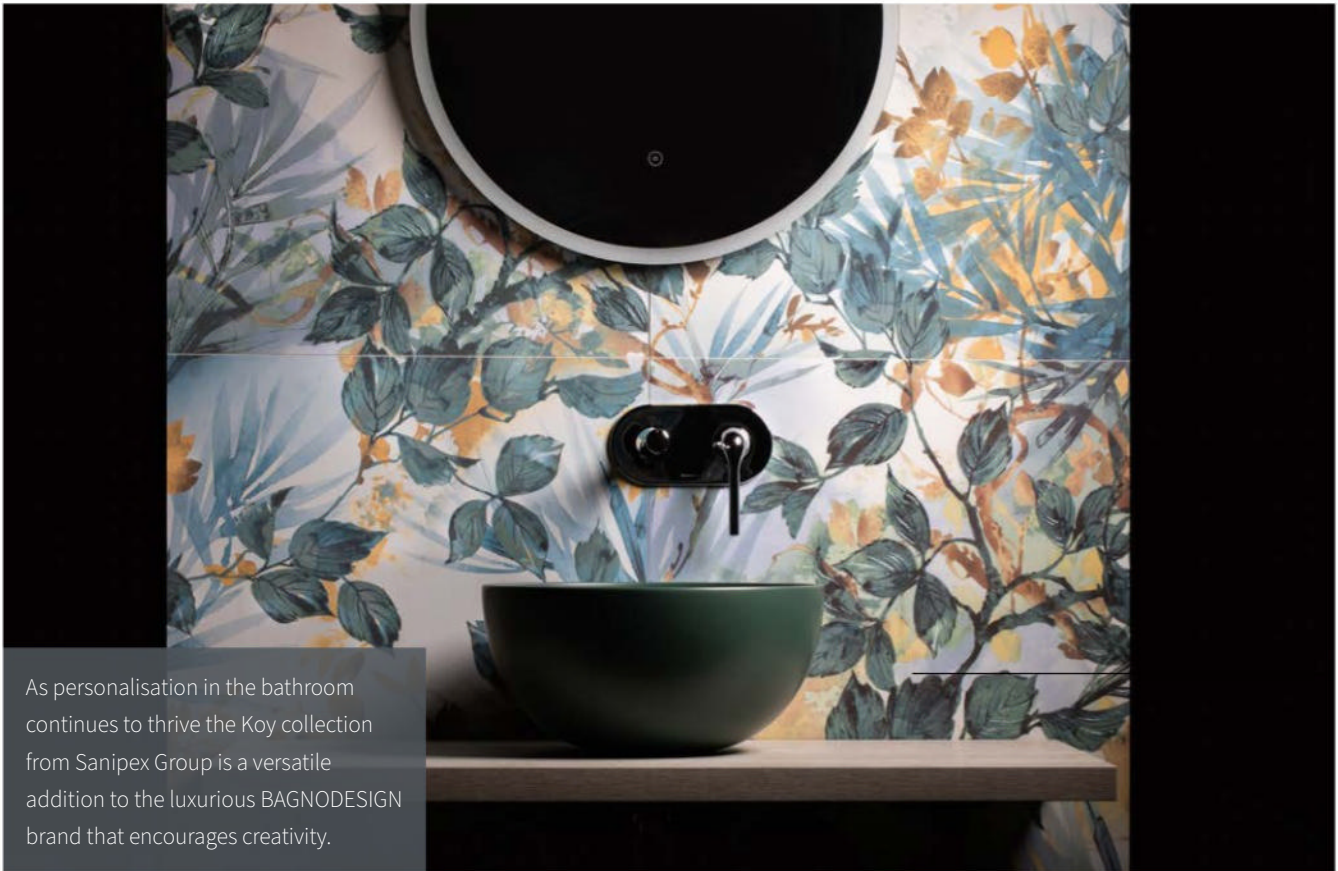

As personalisation in the bathroom continues to thrive the Koy collection from Sanipex Group is a versatile addition to the luxurious BAGNODESIGN brand that encourages creativity.

On-trend styling with an exotic feel is at the essence of Koy. With a sleek finish, clear lines, and effortless curves, the simplistic design of the range is clear, yet its versatile design allows a blend of options to personalise the bathroom.

At the heart of the range is the Koy Round Countertop Washbasin, available in 10 colourways, enabling consumers to introduce brightness and boldness into their home in the most stylish of ways.

With colours ranging from daring yet delightful Buttercup Yellow, to the more dulcet tones of Matt Green and Thistle Blue, the Koy Round Washbasin is a striking piece of sanitaryware for the bathroom and for the

bathroom showroom. Team the basin with a wall-mounted WC in 4 matching shades and complete the look with stunning Koy brassware in finishes including Chrome, Matt Black and Brushed Nickel.

The Koy collection also features a rectangular countertop washbasin, two freestanding bathtubs and illuminated mirrors. Soft curves and rounded edges are present throughout the range, bringing a sense of calm and wellbeing to the modern bathroom.



For more details, contact Sanipex Group on **01924 233977** or visit **[www.bagnodesign.it](http://www.bagnodesign.it)**



# A GRAND ENTRANCE



A new staircase can completely transform a hallway, not just in the way it looks but how the space is used. Assessing the available space and rearranging the layout of the hallway to use the space more efficiently can add valuable square metres to a home's

entrance. A specialist staircase designer will consider all options, including changing the staircase direction to create a better flow of movement, using an open tread design to maximise natural light and reviewing materials used to ensure the stair is in keeping with the period of the property. Sometimes it can mean commissioning a whole new staircase while other times, changing the balustrade on an existing structure will make all the difference.

Most importantly, the staircase should integrate perfectly with the property it is designed for. Only 60% of the design is about the staircase, 40% is about how it interfaces with the property. Bisca will incorporate materials, textures and colours from the interior scheme into the new staircase, so it's a perfect fit in the home.

Bespoke staircase specialist Bisca designs and makes award-winning staircases, built entirely in the company's own workshop

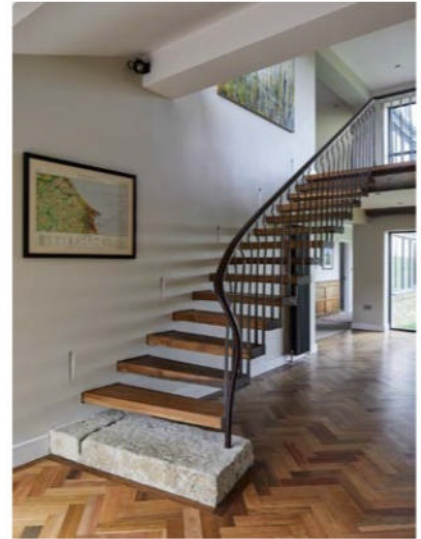

in North Yorkshire. Each commission is the handiwork of a dedicated team of multi-skilled craftspeople who combine traditional disciplines, including metalwork, blacksmithing, cabinetry, joinery and leatherworking with precision-engineered designs and modern materials.

[www.bisca.co.uk](http://www.bisca.co.uk) | Tel **01439 771702** | [staircase@bisca.co.uk](mailto:staircase@bisca.co.uk)

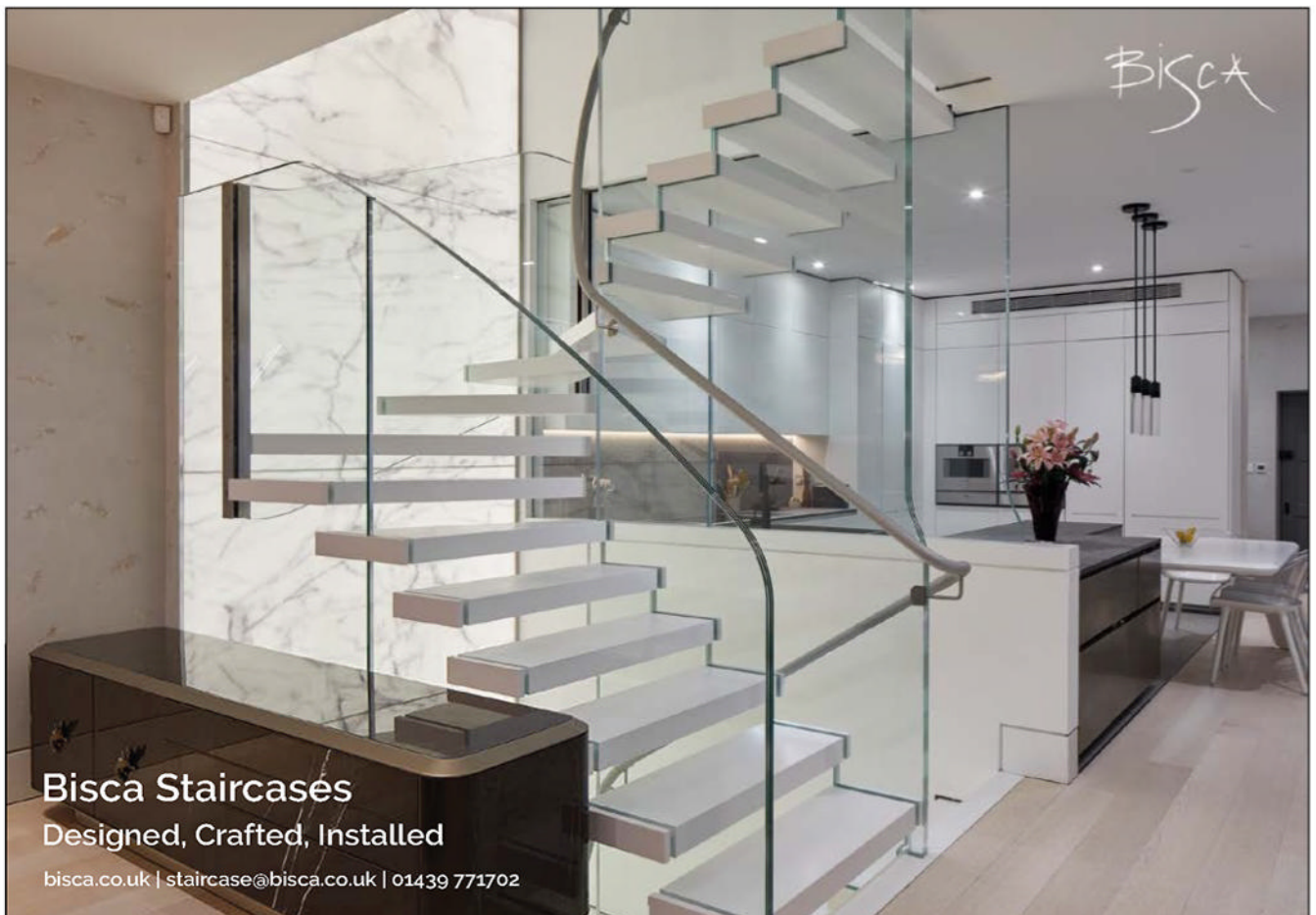

**Bisca Staircases**  
Designed, Crafted, Installed

[bisca.co.uk](http://bisca.co.uk) | [staircase@bisca.co.uk](mailto:staircase@bisca.co.uk) | 01439 771702

# hard surfaces

co-located  
with **the Natural  
StoneShow**

Where innovation meets design | 6-8 June 2023 | **EXCEL  
LONDON**



**Be inspired...**

For the latest innovations in  
surface design.

[hardsurfaces.co.uk](http://hardsurfaces.co.uk)

# the Natural StoneShow

co-located with **hard surfaces**

The UK stone industry event

6-8 June 2023

EXCEL  
LONDON

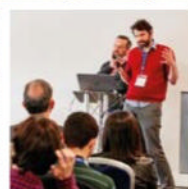
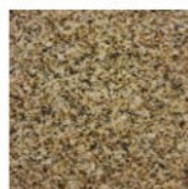
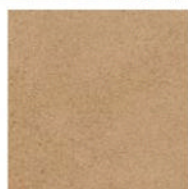
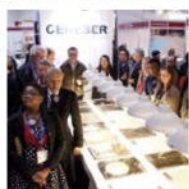

Stone, the natural sustainable choice for your interior design.

Register for your **free** ticket now!

[stoneshow.co.uk/register](https://stoneshow.co.uk/register)

